

Plastics piping and ducting systems — Thermoplastics pipes — Determination of tensile properties

The European Standard EN 638:1994 has the status of a
British Standard

UDC 621.643.2-036:620.172.25

NO COPYING WITHOUT BSI PERMISSION EXCEPT AS PERMITTED BY COPYRIGHT LAW



Committees responsible for this British Standard

The preparation of this British Standard was entrusted to Technical Committee PRI/61, Plastic piping systems and components, upon which the following bodies were represented:

British Gas plc
 British Plastics Federation
 British Plumbing Fittings Manufacturers' Association
 British Valve and Actuator Manufacturers' Association
 Department of the Environment (British Board of Agreement)
 Department of the Environment (Building Research Establishment)
 Department of the Environment (Property and Buildings Directorate)
 Department of Transport
 Electricity Association
 Federation of Civil Engineering Contractors
 Health and Safety Executive
 Institute of Building Control
 Institute of Materials
 Institution of Civil Engineers
 Institution of Gas Engineers
 Institution of Water and Environmental Management
 National Association of Plumbing, Heating and Mechanical Services Contractors
 Pipeline Industries Guild
 Plastics Land Drainage Manufacturers' Association
 Society of British Gas Industries
 Society of British Water Industries
 Water Companies Association
 Water Services Association of England and Wales

The following bodies were also represented in the drafting of the standard, through subcommittees and panels:

ERA Technology Ltd.
 Engineering Equipment and Materials Users' Association
 RAPRA Technology Ltd.

This British Standard, having been prepared under the direction of the Sector Board for Materials and Chemicals, was published under the authority of the Standards Board and comes into effect on 15 May 1995

© BSI 09-1999

The following BSI references relate to the work on this standard:
 Committee reference PRI/61
 Draft for comment 92/37673 DC

ISBN 0 580 23961 6

Amendments issued since publication

Amd. No.	Date	Comments

Contents

	Page
Committees responsible	Inside front cover
National foreword	ii
<hr/>	
Foreword	2
1 Scope	3
2 Normative references	3
3 Principle	3
4 Apparatus	3
5 Test pieces	3
6 Conditioning	4
7 Test temperature	4
8 Procedure	4
9 Expression of results	5
10 Repetition	6
11 Test report	6
<hr/>	
Annex A (informative) Machining of test pieces	7
<hr/>	
Figure 1 — Obtaining test pieces	5
Figure A.1 — Test piece assembly jig during machining	7
Figure A.2 — Machined test piece	8
Figure A.3 — Profile of detachable blades	8
<hr/>	
Table 1 — Number of sectors or strips related to nominal outside diameter	4



MAHCO

National foreword

This British Standard has been prepared by Technical Committee PRI/61 and is the English language version of EN 638:1994 *Plastics piping and ducting systems — Thermoplastics pipes — Determination of tensile properties*, published by the European Committee for Standardization (CEN).

It is incorporated into BS 2782 *Methods of testing plastics:*

Part 11: *Thermoplastics pipes, fittings and valves*, as Method 1110B:1995.

This test method is incorporated into BS 2782 for association with related test methods for plastics materials and plastics piping components.

This test method has been prepared for reference by other standards under preparation by CEN for specification of plastics piping systems and components. It has been implemented to enable experience of the method to be gained and for use for other fresh applications.

It is also for use for the revision or amendment of other national standards as practicable, but it should not be presumed to apply to any existing standard or specification which contains or makes reference to a different test method until that standard/specification has been amended or revised to make reference to this method and adjust any requirements as appropriate.

Method 1110:1989 of BS 2782 will be withdrawn when no longer required to support national standards, specifically BS 4576-1:1989 and BS 4660:1989, pending their replacement by CEN standards currently under preparation for such types of piping systems.

WARNING. This British Standard, which is the English language version of EN 638:1994, does not necessarily detail all the precautions necessary to meet the requirements of the Health and Safety at Work etc. Act 1974. Attention should be paid to any appropriate safety precautions and the method should be operated only by trained personnel.

A British Standard does not purport to include all the necessary provisions of a contract. Users of British Standards are responsible for their correct application.

Compliance with a British Standard does not of itself confer immunity from legal obligations.

Summary of pages

This document comprises a front cover, an inside front cover, pages i and ii, the EN title page, pages 2 to 8 and a back cover.

This standard has been updated (see copyright date) and may have had amendments incorporated. This will be indicated in the amendment table on the inside front cover.

UDC 621.643.2-036:620.172.25

Descriptors: Pipelines, plastic tubes, tension tests, determination, characteristics, tensile stress, elongation at break

English version

Plastics piping and ducting systems — Thermoplastics pipes — Determination of tensile properties

Systèmes de canalisations et de gaines
plastiques — Tubes thermoplastiques —
Détermination des propriétés en traction

Kunststoff-Rohrleitungs- und
Schutzrohrsysteme — Rohre aus
Thermoplasten — Bestimmung der
Eigenschaften im Zugversuch

This European Standard was approved by CEN on 1994-04-11. CEN members are bound to comply with the CEN/CENELEC Internal Regulations which stipulate the conditions for giving this European Standard the status of a national standard without any alteration.

Up-to-date lists and bibliographical references concerning such national standards may be obtained on application to the Central Secretariat or to any CEN member.

This European Standard exists in three official versions (English, French, German). A version in any other language made by translation under the responsibility of a CEN member into its own language and notified to the Central Secretariat has the same status as the official versions.

CEN members are the national standards bodies of Austria, Belgium, Denmark, Finland, France, Germany, Greece, Iceland, Ireland, Italy, Luxembourg, Netherlands, Norway, Portugal, Spain, Sweden, Switzerland and United Kingdom.

MAHCO
CEN

European Committee for Standardization
Comité Européen de Normalisation
Europäisches Komitee für Normung

Central Secretariat: rue de Stassart 36, B-1050 Brussels

Foreword

This standard was prepared by CEN/TC 155, Plastics piping systems and ducting systems.

This standard is based on the text for ISO/DIS 6259-1 *Thermoplastics pipes — Tensile properties — Determination and basic specifications — Part 1: General test method*, prepared by the International Organization for Standardization (ISO). It is a modification of the text for ISO/DIS 6259-1 for reasons of alignment with texts of other standards on test methods.

The modifications are:

- test parameters, except those common to all thermoplastics, are omitted;
- no material-dependent or performance requirements are given;
- editorial changes have been introduced.

Annex A, which is informative, gives guidance on machining equipment and conditions.

The material-dependent parameters and/or performance requirements are incorporated in the systems standard(s) concerned.

No existing European Standard is superseded by this standard.

This standard is one of a series of standards on test methods which support Systems Standards for plastics piping systems and ducting systems.

This European Standard shall be given the status of a national standard, either by publication of an identical text or by endorsement, at the latest by October 1994, and conflicting national standards shall be withdrawn at the latest by October 1994.

According to the CEN/CENELEC Internal Regulations, the following countries are bound to implement this European Standard: Austria, Belgium, Denmark, Finland, France, Germany, Greece, Iceland, Ireland, Italy, Luxembourg, Netherlands, Norway, Portugal, Spain, Sweden, Switzerland and United Kingdom.

MAHCO

1 Scope

This standard specifies a method for determining the short term tensile properties in the longitudinal direction and, in particular,

- the tensile stress at yield and/or at maximum load, and
- elongation at break

of thermoplastics pipes and ducts.

This standard is applicable to all types of thermoplastics pipes, regardless of their intended use.

NOTE The tests of tensile properties are intended to be regarded as tests of material in the form of pipe and not as tests of the pipe itself. The values obtained by this test should not be used as design values for the pipe.

2 Normative references

This European Standard incorporates by dated or undated reference, provisions from other publications. These normative references are cited at the appropriate places in the text and the publications are listed hereafter. For dated references, subsequent amendments to or revisions of any of these publications apply to this European Standard only when incorporated in it by amendment or revision. For undated references the latest edition of the publication referred to applies.

ISO/DIS 527-2.3, *Plastics — Determination of tensile properties — Part 2: Test conditions for moulding and extrusion plastics*.

ISO 5893:1985, *Rubber and plastics test equipment — Tensile, flexural and compression types (constant rate of traverse) — Description*.

3 Principle

Test pieces of specified shape and dimensions are taken from a thermoplastics pipe, in the longitudinal direction, by punch cutting or machining, depending upon the size and the material of the pipe.

The tensile properties are determined using a tensile testing machine under specified short term conditions.

NOTE It is assumed that the following test parameters are set by the standard making reference to this standard:

- a) the rate of movement of the driven grip (the speed of testing) (see 4.1 and 8.4);
- b) the test piece shape and dimensions (see 5.1);
- c) the number of test pieces to be tested (see 5.2.1.2 and 5.2.1.3);
- d) the method for obtaining test pieces (see 5.2.2);
- e) if necessary, treatment (e.g. heating) of strips from which test pieces are to be cut (see 5.2.2.2);
- f) the initial gauge length (initial distance between reference marks) of the test piece (see 5.2.3) and the applicable extensometer grade in accordance with ISO 5893:1985 (see 4.4);

g) if necessary, the need to calculate standard deviations (see 9.3).

4 Apparatus

4.1 Tensile testing machine, conforming to ISO 5893:1985, for the specified rate of movement of the driven grip.

4.2 Grips, for holding the test piece, conforming to ISO 5893:1985, which shall be fixed to the machine in such a way that they move freely into alignment as soon as any force is applied, so that the longitudinal axis of the test piece coincides with the direction of the force along the centreline of the grip assembly.

4.3 Force indicator, capable of showing or recording with an accuracy conforming to grade A of ISO 5893:1985 the total tensile force to which the test piece held in the grips is subjected when tested at the speed specified.

4.4 Extensometer, constructed and attached in conformity to ISO 5893:1985 for the specified gauge length and extensometer grade.

NOTE It is desirable, but not essential, for this instrument to record this length (or any variation of it) automatically as a function of the stress in the test piece.

4.5 Micrometer or equivalent, giving readings to 0,01 mm or smaller, for measuring the thickness and width of the test pieces.

4.6 Punch cutting die, with a specified profile (see 5.1) and clean, sharp cutting edges free from notches.

4.7 Milling machine plus cutter(s), capable of preparing the specified test pieces (see 5.1 and 5.2.2.3).

5 Test pieces

5.1 Shape

The test piece shall comprise a dumb-bell having a plan shape specified by the referring standard (see clause 3) and selected, if applicable, from the types of test specimen given in ISO/DIS 527-2.3. The thickness of the test piece shall be the full wall thickness of the pipe from which it is taken.

5.2 Preparation

5.2.1 Obtaining sample strips from a pipe

5.2.1.1 General

Cut strips, in accordance with 5.2.1.2 or 5.2.1.3 as follows, from the pipe as supplied, i.e. without prior heating or flattening, so that the longitudinal axis of each strip is parallel to the axis of the pipe.

For pipes classified by nominal outside diameters 5.2.1.2 and 5.2.1.3 apply.

For pipes classified otherwise, to apply 5.2.1.2 or 5.2.1.3, read “minimum permissible outside diameter” in place of “nominal outside diameter”.

5.2.1.2 Pipes having a nominal outside diameter of less than 75 mm

Unless otherwise specified (see clause 3), obtain at least five strips each approximately 150 mm long by cutting the strips from the minimum number of corresponding lengths of pipe necessary for the longitudinal axes of the strips to be uniformly distributed around the pipe.

5.2.1.3 Pipes having a nominal outside diameter of 75 mm or greater

Use a length of pipe approximately 150 mm.

If the number of test pieces is specified (see clause 3), for each test piece required cut one strip from the length in such a way that the strips are equally distributed along the circumference of the pipe, e.g. as shown in Figure 1, and, if necessary, using additional length(s) of pipe. Otherwise, divide the circumference of the pipe length into a number of sectors, depending on the outside diameter of the pipe as given in Table 1, and cut one strip from each sector.

Table 1 — Number of sectors or strips related to nominal outside diameter

Nominal outside diameter, mm	≥ 75 and < 280	≥ 280 and < 450	≥ 450 and < 710	≥ 710 and < 1 000
Number of sectors or strips	5	7	10	16

5.2.2 Obtaining test pieces from strips

5.2.2.1 General

Cut one test piece from the centre of each strip taken from the length of pipe (see 5.2.1) either by punch cutting in accordance with 5.2.2.2 or by machining in accordance with 5.2.2.3, as specified.

5.2.2.2 Punch cutting method

If applicable, precondition the strip immediately before using the punch cutting die (see 4.6) so that the punch is applied to the inner pipe wall surface of the strip with sufficient uniform pressure to pass right through the wall thickness in a single stroke.

NOTE For some materials, preheating of the strip may be specified by the referring standard.

5.2.2.3 Machining method

Produce the test piece by milling, where necessary using a milling jig.

The shape of the milling cutter and the machining conditions (speed of rotation and advance) are at the discretion of the operator, provided they are chosen so as to avoid any heating of the test piece and/or damage to its surface, such as cracks, scratches or other visible flaws, to an extent that would affect the tensile properties to be measured. Reject therefore any test pieces with such faults.

NOTE Attention is drawn to ISO 2818¹⁾ for guidance on the machining procedure and to additional guidance in Annex A, which is normative.

5.2.3 Gauge marks

Using devices or materials which do not scratch, imprint or otherwise affect the characteristics of the tensile properties of the material concerned, establish two gauge marks or positions equidistant from the ends of the calibrated length of the test piece [see item f) of the note to clause 3].

6 Conditioning

The test pieces shall be conditioned at (23 ± 2) °C for not less than 1 h in water or 2 h in air, except in cases of dispute when the minimum period shall be 2 h in water or 4 h in air.

7 Test temperature

The test temperature shall be (23 ± 2) °C.

8 Procedure

8.1 Measure, to within 0,01 mm, the minimum width and the minimum thickness of the central part of the test piece between the gauge marks and calculate the minimum cross-sectional area, *A*.

8.2 Place the test piece in the tensile testing machine (see 4.1) so that the axial alignment coincides closely with the direction of pull. Clamp the grips (see 4.2) uniformly and sufficiently tightly to prevent any slipping of the test piece.

8.3 Where necessary, place and adjust the extensometer (see 4.4) on the reference length (the part between the gauge marks) of the test piece.

¹⁾ ISO 2818:1980 *Plastics — Preparation of test specimens by machining*

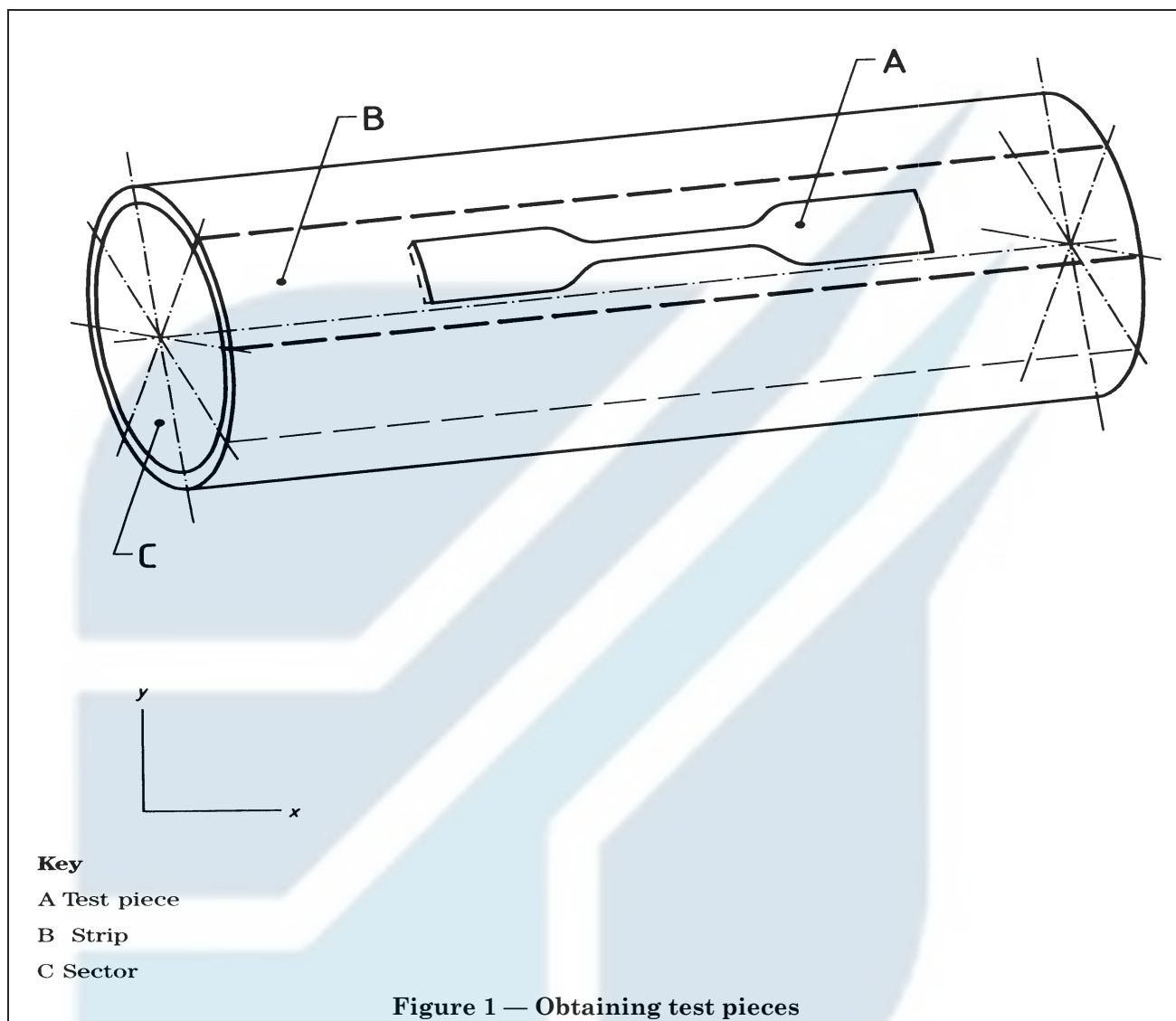

Figure 1 — Obtaining test pieces

8.4 Set the speed of testing to the value specified and start the machine.

8.5 Record the results in one of the following ways:

- a) record the curve of force, or stress, against deformation, or strain, up to rupture of the test piece and record on this curve the force, or stress, at the yield point and at the maximum load and the gauge length at the moment of rupture;
- b) record directly the values of the force at yield and the gauge length at the moment of rupture.

Discard any test pieces which have slipped in the grips and any for which rupture has occurred outside the gauge marks and repeat the test on a corresponding number of test pieces.

9 Expression of results

9.1 Tensile stress at yield point and maximum load

For each test piece, calculate the tensile stress at yield and at maximum load using the following equation:

$$\sigma = \frac{F}{A}$$

where

- σ is the stress at yield (σ_y) or maximum load (σ_{\max}), in megapascals (MPa)^a;
- F is the force at yield or at maximum load, in newtons;
- A is the minimum initial cross-sectional area of the test piece, in square millimetres.

^a 1 MPa = 1 N/mm² = 10⁶ N/m²

Express the results to three significant figures.

9.2 Elongation at break

For each test piece, calculate the elongation at break using the following equation:

$$\varepsilon = \frac{L - L_0}{L_0} \cdot 100$$

where

- ε is the elongation at break, as a percentage;
- L is the gauge at break, in millimetres;
- L_0 is the initial gauge length, in millimetres.

Express the results to three significant figures.

9.3 Arithmetic means and standard deviations

If required, e.g. for a type test, calculate for each property (i.e. the stress at yield and elongation at break of the test piece) the arithmetic mean \bar{x} and, using the following equation, the standard deviation s :

$$s = \left[\frac{\sum (x - \bar{x})^2}{n - 1} \right]^{0,5}$$

where

- x is the individual value for the respective property for each test piece;
- \bar{x} is the arithmetic mean for the respective property;
- n is the number of test pieces.

10 Repetition

If abnormal results are obtained on one or more test pieces, repeat the tests on twice the number of such test pieces cut, if possible, from the same length of pipe.

EXAMPLE. If out of five test pieces tested, two give abnormal results, repeat the test on a further four test pieces.

11 Test report

The test report shall include the following information:

- a) a reference to this standard and the referring standard;
- b) the complete identification of the pipe tested, including the constituent material, type, origin and nominal dimensions;
- c) the type (shape) of test piece used and the cutting method by which it was prepared;
- d) the conditioning medium (water or air), period and temperature;
- e) the test temperature;
- f) the number of test pieces tested;
- g) the speed of testing;
- h) as applicable, the stress yield, σ_y , and/or the stress, σ_{\max} , at maximum load, (individual values, arithmetic mean and, if applicable, the standard deviation) (see 9.1 and 9.3);
- i) the elongation at break (individual values, arithmetic mean and, if applicable, the standard deviation) (see 9.2 and 9.3);
- j) any factors which may have affected the results, such as any incidents or any operating details not specified in this standard: in particular any special features, such as foreign bodies, observed on the test pieces and in the cross section of rupture;
- k) the date of test.

MAHCO

Annex A (informative) Machining of test pieces

A.1 General

This annex gives advice on the machining of one of the sizes of test pieces expected to be used.

A.2 Machining

For the size of test pieces shown in Figure A.1 and Figure A.2, several test pieces can be machined simultaneously. For this, a test piece assembly jig such as the one shown in Figure A.1 can be used.

A.3 Properties of the mill

The milling tool to be used to mill test pieces (see Figure A.2) should be one of the following types:

- an end mill with one or two teeth;
- a mill with detachable blades having a profile as shown in Figure A.3.

A.4 Conditions for machining

The conditions for machining should be as follows:

- cutter speed: 10 m/min;
- feed: 10 mm/min to 20 mm/min.

NOTE These values may not be applicable to all plastics.

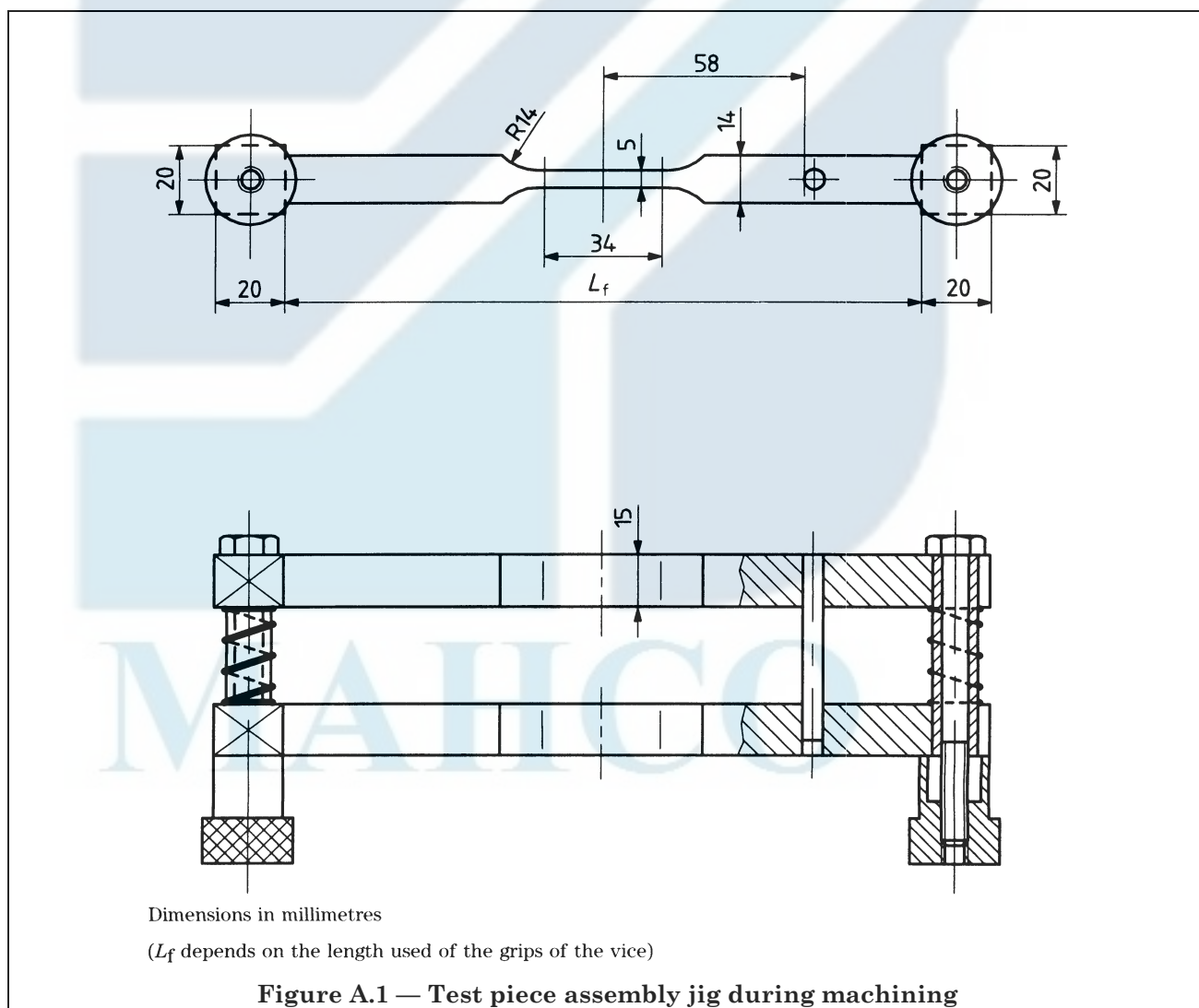

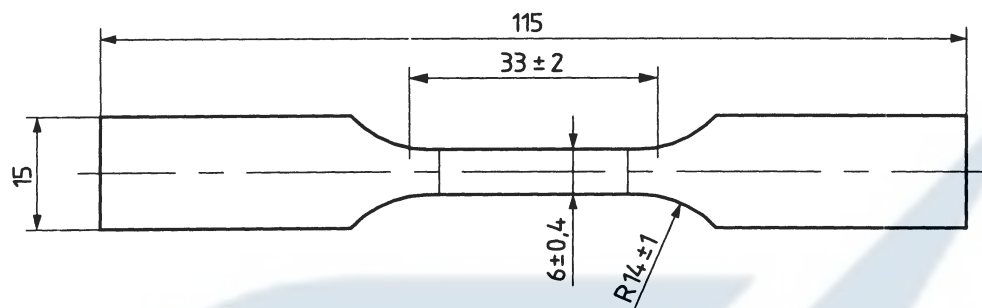

Dimensions in millimetres

Figure A.2 — Machined test piece

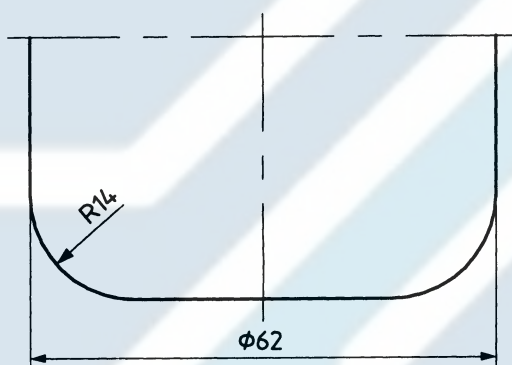

Dimensions in millimetres

Figure A.3 — Profile of detachable blades

MAHCO



MAHCO

BSI — British Standards Institution

BSI is the independent national body responsible for preparing British Standards. It presents the UK view on standards in Europe and at the international level. It is incorporated by Royal Charter.

Revisions

British Standards are updated by amendment or revision. Users of British Standards should make sure that they possess the latest amendments or editions.

It is the constant aim of BSI to improve the quality of our products and services. We would be grateful if anyone finding an inaccuracy or ambiguity while using this British Standard would inform the Secretary of the technical committee responsible, the identity of which can be found on the inside front cover. Tel: 020 8996 9000. Fax: 020 8996 7400.

BSI offers members an individual updating service called PLUS which ensures that subscribers automatically receive the latest editions of standards.

Buying standards

Orders for all BSI, international and foreign standards publications should be addressed to Customer Services. Tel: 020 8996 9001. Fax: 020 8996 7001.

In response to orders for international standards, it is BSI policy to supply the BSI implementation of those that have been published as British Standards, unless otherwise requested.

Information on standards

BSI provides a wide range of information on national, European and international standards through its Library and its Technical Help to Exporters Service. Various BSI electronic information services are also available which give details on all its products and services. Contact the Information Centre. Tel: 020 8996 7111. Fax: 020 8996 7048.

Subscribing members of BSI are kept up to date with standards developments and receive substantial discounts on the purchase price of standards. For details of these and other benefits contact Membership Administration. Tel: 020 8996 7002. Fax: 020 8996 7001.

Copyright

Copyright subsists in all BSI publications. BSI also holds the copyright, in the UK, of the publications of the international standardization bodies. Except as permitted under the Copyright, Designs and Patents Act 1988 no extract may be reproduced, stored in a retrieval system or transmitted in any form or by any means – electronic, photocopying, recording or otherwise – without prior written permission from BSI.

This does not preclude the free use, in the course of implementing the standard, of necessary details such as symbols, and size, type or grade designations. If these details are to be used for any other purpose than implementation then the prior written permission of BSI must be obtained.

If permission is granted, the terms may include royalty payments or a licensing agreement. Details and advice can be obtained from the Copyright Manager. Tel: 020 8996 7070.