

# Thermoplastics pipes, fittings and assemblies for the conveyance of fluids — Determination of the resistance to internal pressure —

## Part 1: General method

The European Standard EN ISO 1167-1:2006 has the status of a  
British Standard

ICS 23.040.45; 23.040.20

## National foreword

This British Standard is the official English language version of EN ISO 1167-1:2006. It is identical with ISO 1167-1:2006. This Standard, together with BS EN 1167-2 supersedes BS EN 921:1994 which is withdrawn.

The UK participation in its preparation was entrusted by Technical Committee PRI/88, Plastic pipes, to Subcommittee PRI/88/4, Test methods, which has the responsibility to:

- aid enquirers to understand the text;
- present to the responsible international/European committee any enquiries on the interpretation, or proposals for change, and keep UK interests informed;
- monitor related international and European developments and promulgate them in the UK.

A list of organizations represented on this subcommittee can be obtained on request to its secretary.

### Cross-references

The British Standards which implement international or European publications referred to in this document may be found in the *BSI Catalogue* under the section entitled “International Standards Correspondence Index”, or by using the “Search” facility of the *BSI Electronic Catalogue* or of British Standards Online.

This publication does not purport to include all the necessary provisions of a contract. Users are responsible for its correct application.

**Compliance with a British Standard does not of itself confer immunity from legal obligations.**

### Summary of pages

This document comprises a front cover, an inside front cover, the EN ISO title page, the EN ISO foreword page, the ISO title page, pages ii to v, a blank page, pages 1 to 8, an inside back cover and a back cover.

The BSI copyright notice displayed in this document indicates when the document was last issued.

### Amendments issued since publication

Amd. No.	Date	Comments

This British Standard was published under the authority of the Standards Policy and Strategy Committee on 31 August 2006

© BSI 2006

ISBN 0 580 49073 4

English Version

Thermoplastics pipes, fittings and assemblies for the  
conveyance of fluids - Determination of the resistance to internal  
pressure - Part 1: General method (ISO 1167-1:2006)

Tubes, raccords et assemblages en matières  
thermoplastiques pour le transport des fluides -  
Détermination de la résistance à la pression interne - Partie  
1: Méthode générale (ISO 1167-1:2006)

Rohre, Formstücke und Zubehör aus thermoplastischen  
Kunststoffen für den Transport von Flüssigkeiten -  
Bestimmung der Widerstandsfähigkeit gegen inneren  
Überdruck - Teil 1: Allgemeines Prüfverfahren (ISO 1167-  
1:2006)

This European Standard was approved by CEN on 23 January 2006.

CEN members are bound to comply with the CEN/CENELEC Internal Regulations which stipulate the conditions for giving this European Standard the status of a national standard without any alteration. Up-to-date lists and bibliographical references concerning such national standards may be obtained on application to the Central Secretariat or to any CEN member.

This European Standard exists in three official versions (English, French, German). A version in any other language made by translation under the responsibility of a CEN member into its own language and notified to the Central Secretariat has the same status as the official versions.

CEN members are the national standards bodies of Austria, Belgium, Cyprus, Czech Republic, Denmark, Estonia, Finland, France, Germany, Greece, Hungary, Iceland, Ireland, Italy, Latvia, Lithuania, Luxembourg, Malta, Netherlands, Norway, Poland, Portugal, Romania, Slovakia, Slovenia, Spain, Sweden, Switzerland and United Kingdom.



EUROPEAN COMMITTEE FOR STANDARDIZATION  
COMITÉ EUROPÉEN DE NORMALISATION  
EUROPÄISCHES KOMITEE FÜR NORMUNG

Management Centre: rue de Stassart, 36 B-1050 Brussels



MAHCO

INTERNATIONAL  
STANDARD

ISO  
1167-1

First edition  
2006-02-01

---

---

**Thermoplastics pipes, fittings and  
assemblies for the conveyance of  
fluids — Determination of the resistance  
to internal pressure —**

**Part 1:  
General method**

*Tubes, raccords et assemblages en matières thermoplastiques pour le  
transport des fluides — Détermination de la résistance à la pression  
interne —*

*Partie 1: Méthode générale*

MAHCO



Reference number  
ISO 1167-1:2006(E)



## Contents

Page

Foreword.....	iv
Introduction .....	v
1 Scope .....	1
2 Normative references .....	1
3 Terms and definitions.....	1
4 Principle .....	2
5 Apparatus .....	2
6 Test pieces .....	4
6.1 Preparation of test pieces.....	4
6.2 Number of test pieces .....	4
7 Calculation of test pressure .....	4
7.1 General.....	4
7.2 Pressure calculations based on the measured dimensions of the test piece .....	5
7.3 Pressure calculations based on the nominal dimensions of the test piece.....	5
7.4 Pressure calculations based on SDR of pipe(s) of the test piece .....	5
8 Calibration and accuracy of the apparatus .....	6
9 Conditioning.....	6
10 Test procedure .....	6
11 Test report .....	7

MAHCO



## Foreword

ISO (the International Organization for Standardization) is a worldwide federation of national standards bodies (ISO member bodies). The work of preparing International Standards is normally carried out through ISO technical committees. Each member body interested in a subject for which a technical committee has been established has the right to be represented on that committee. International organizations, governmental and non-governmental, in liaison with ISO, also take part in the work. ISO collaborates closely with the International Electrotechnical Commission (IEC) on all matters of electrotechnical standardization.

International Standards are drafted in accordance with the rules given in the ISO/IEC Directives, Part 2.

The main task of technical committees is to prepare International Standards. Draft International Standards adopted by the technical committees are circulated to the member bodies for voting. Publication as an International Standard requires approval by at least 75 % of the member bodies casting a vote.

Attention is drawn to the possibility that some of the elements of this document may be the subject of patent rights. ISO shall not be held responsible for identifying any or all such patent rights.

ISO 1167-1 was prepared by Technical Committee ISO/TC 138, *Plastics pipes, fittings and valves for the transport of fluids*, Subcommittee SC 5, *General properties of pipes, fittings and valves of plastic materials and their accessories — Test methods and basic specifications*.

This first edition of ISO 1167-1, together with ISO 1167-2, cancels and replaces ISO 1167:1996 and, together with ISO 1167-3, cancels and replaces ISO 12092:2000, of which it constitutes a technical revision.

ISO 1167 consists of the following parts, under the general title *Thermoplastics pipes, fittings and assemblies for the conveyance of fluids — Determination of the resistance to internal pressure*:

- *Part 1: General method*
- *Part 2: Preparation of pipe test pieces*
- *Part 3: Preparation of components*
- *Part 4: Preparation of assemblies*

MAHCO



## Introduction

Tests for determining resistance to internal pressure are essential for assessing the properties and durability of thermoplastics piping system parts. In fact, they constitute a basis for determining short-term and long-term characteristics.

Many International Standards contain requirements for the determination of the resistance to pressure of pipes, fittings or assemblies. All these documents describe the equipment for pressurizing the different test pieces considered as well as the testing procedure and the test report.

In order to avoid unnecessary repetition, it is desirable to group together all these documents and to establish one International Standard divided into several parts.

ISO 1167-1 contains a description of the equipment used to pressurize test pieces, the testing procedure to be applied and the test report.

ISO 1167-2, ISO 1167-3 and ISO 1167-4 describe the method of preparation of test pieces corresponding to each case considered: pipes, components or assemblies.

The logo for MAHCO is a large, light blue stylized graphic consisting of several overlapping geometric shapes, including a large 'M' and 'C' that form a central 'H' shape. Below this graphic, the word 'MAHCO' is written in a large, light blue, serif font.

MAHCO



www.mahco.com

# Thermoplastics pipes, fittings and assemblies for the conveyance of fluids — Determination of the resistance to internal pressure —

## Part 1: General method

### 1 Scope

This part of ISO 1167 specifies a general test method for determining the resistance to internal hydrostatic pressure at a given temperature of thermoplastics pipes, fittings and piping systems for the transport of fluids.

The method accommodates water-in-water, water-in-air and water-in-liquid tests.

### 2 Normative references

The following referenced documents are indispensable for the application of this document. For dated references, only the edition cited applies. For undated references, the latest edition of the referenced document (including any amendments) applies.

ISO 1167-2:2006, *Thermoplastics pipes, fittings and assemblies for the conveyance of fluids — Determination of the resistance to internal pressure — Part 2: Preparation of pipe test pieces*

ISO 1167-3, *Thermoplastics pipes, fittings and assemblies the conveyance of fluids — Determination of the resistance to internal pressure — Part 3: Preparation of components*<sup>1)</sup>

ISO 1167-4, *Thermoplastics pipes, fittings and assemblies for the conveyance of fluids — Determination of the resistance to internal pressure — Part 4: Preparation of assemblies*<sup>1)</sup>

ISO 3126, *Plastics piping systems — Plastics components — Determination of dimensions*

ISO 9080, *Plastics piping and ducting systems — Determination of the long-term hydrostatic strength of thermoplastics pipe materials in pipe form by extrapolation*

### 3 Terms and definitions

For the purposes of this document, the following terms and definitions apply.

#### 3.1 component

fitting or valve, in single or multiple form, that is supplied as an integral unit

#### 3.2 standard dimension ratio SDR

ratio of the nominal outside diameter  $d_n$  of a pipe to its nominal wall thickness  $e_n$

---

1) To be published.

## 4 Principle

After conditioning, test pieces are subjected to a specified constant internal hydrostatic pressure for a specified period of time or until a test piece or pieces fail.

Throughout the test, the test pieces are kept in an environment at a specified constant temperature: this is either water ("water-in-water" test), another liquid ("water-in-liquid" test) or air ("water-in-air" test).

The following test parameters shall be specified by the standard or specification making reference to this part of ISO 1167:

- a) the type of end cap to be used (see 5.1 and ISO 1167-2:2006, 4.1);
- b) the test temperature;
- c) for evaluation purposes, the SDR or S-series or size of pipe or fitting to be used;
- d) the number of test pieces;
- e) the test pressure,  $p$ , or the circumferential (hoop) stress,  $\sigma$ , to be induced by the test pressure;
- f) the type of test, i.e. "water-in-water", "water-in-liquid" or "water-in-air";
- g) the duration of the test under pressure and the criteria for a failure;
- h) the requirements, or patterns of requirements, if any, which determine the initiation of additional testing.

## 5 Apparatus

**5.1 End caps**, fixed to the ends of the test piece. By means of an appropriate system or procedure, end caps shall allow sealing and connection to the pressurizing equipment and shall allow purging of the air before testing.

The end caps shall be one of the following types.

**Type A:** fittings rigidly connected to the test piece but not to each other, and hence transmitting the hydrostatic end thrust to the test piece, e.g. as shown in Figure 1, or equivalent. They may comprise flanged plates on the ends of a large diameter pipe, optionally fused when flanges, caps, plugs or plates are of a compatible material to the test pieces.

**Type B:** sockets, made of metal, fitted with joints ensuring sealing onto the external surface of the test piece and connected to one another, and hence not transmitting the hydrostatic end thrust to the test piece. They may comprise one or more metal rods, see Figure 1, allowing sufficient longitudinal movement at the ends of the test pieces, to avoid buckling due to thermal expansion. If external rods are used, contact of the outside surface of the test piece with one or several rods shall be avoided during the test. In this case, the test shall be disregarded.

Other than toothed grips, any sharp edges which would come into contact with the outside surface of the pipe shall be rounded off.

The constituent material of the end cap might have an adverse effect on the test piece under test and such materials should therefore be avoided as far as possible.

For testing of components, the end caps shall be replaced by pressure-tight devices as specified in ISO 1167-3.

End caps of type A shall be used for determination of the long-term hydrostatic strength of materials in accordance with ISO 9080.

**NOTE** It is recognized that times to failure can be different depending upon the type of end caps used.

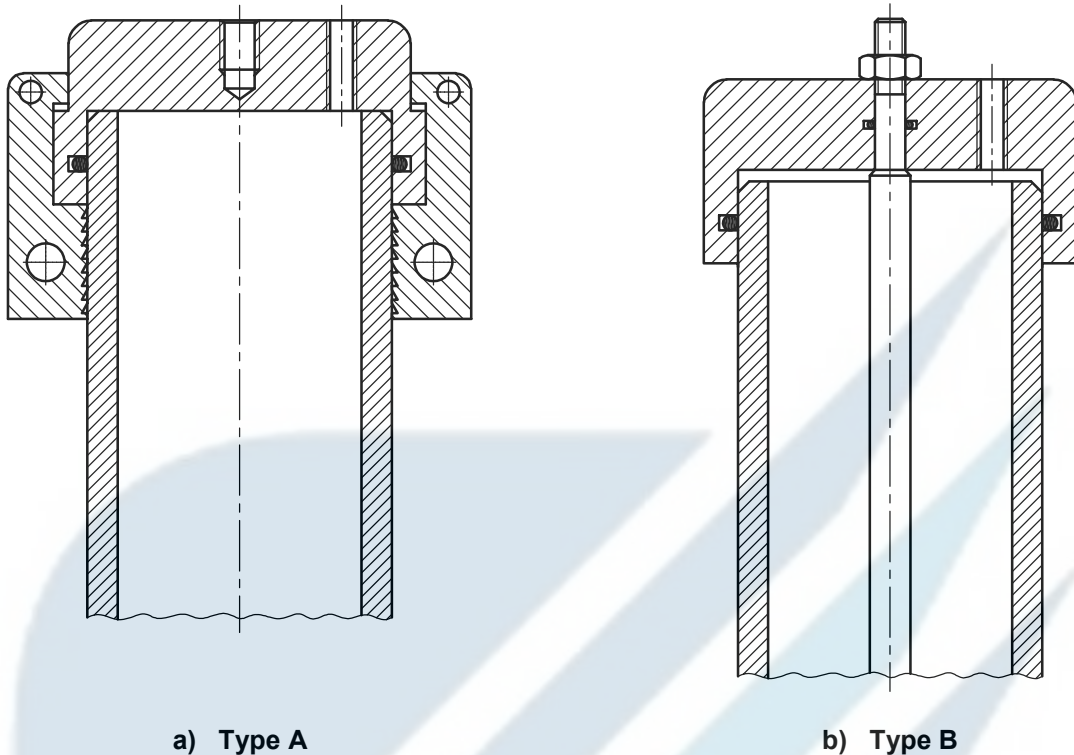

Figure 1 — Examples of end caps for internal pressure testing

**5.2 Tank**, filled with water or other liquid, kept at a constant temperature as specified in the referring standard to within  $\pm 1$  °C, or **oven**, the temperature of which shall be kept at the specified value to within  $\pm 1$  °C.

When an environment other than water is used, necessary precautions shall be taken, in particular those concerning safety and any interaction between liquid and the material(s) of the test piece.

When environments other than water are used, tests which are intended to be comparative shall be carried out in the same environment.

As the results are strongly influenced by temperature, the tolerance on temperature should be kept as small as possible within the specified limits e.g. by using forced circulation of the fluid.

When testing in air, the pipe surface temperature should be checked in addition to the air.

Potable water should be used and it is necessary to avoid contamination of the water by any substance likely to affect the results, e.g. detergents, lubricants.

**5.3 Support or hangers**, enabling test pieces to be placed in the tank or oven (5.2) such that contact between them or with the sidewalls of the tank/oven is avoided as far as possible so as not to influence the test results.

**5.4 Pressurizing equipment**, capable of applying the required pressure gradually and smoothly in accordance with Clause 9 and then of keeping this indicated (or measured) pressure to within  $\pm 1$  % for the duration of the test.

As the results are strongly influenced by pressure, the tolerance on pressure should be kept as small as possible within the specified limits.

The pressure should preferably be applied individually to each test piece. However, the use of equipment enabling the pressure to be applied simultaneously to several test pieces is also permitted if there is no



danger of interference when failure occurs (e.g. by the use of an isolation valve or a test based on the first failure in a batch).

To maintain the pressure within the specified tolerance, a system should be introduced which automatically controls the pressure within this specified tolerance (e.g. due to expansion of the test piece).

**5.5 Pressure measurement devices**, capable of checking conformity to the specified test pressure. The range of the gauge shall be such that the required pressure setting shall lie within the calibrated range of the device used (see Clause 7).

The pressure measurement devices shall not contaminate the test fluid.

In case of dispute, the reference level of the pressure device shall be equal to the water level in the tank.

Master gauges for calibration of the apparatus should be used.

It is recommended to use equipment which is capable of stopping the timer (5.8) in event of failure or leakage and closing the pressure circuit to the test piece concerned.

**5.6 Dimension measuring equipment**, conforming to ISO 3126.

**5.7 Temperature measuring equipment**, capable of checking conformity to the specified test temperature (see 5.2).

**5.8 Timer**, capable of recording the duration of the pressure applications up to the moment of failure or leakage, to within 0,5 % of the expected testing time.

## 6 Test pieces

### 6.1 Preparation of test pieces

The preparation of test pieces shall conform to ISO 1167-2, ISO 1167-3 or ISO 1167-4, as applicable.

Measure and record test piece component parameters, e.g. preparation conditions, dimensions, as necessary.

### 6.2 Number of test pieces

Prepare a minimum of three test pieces unless otherwise specified in the referring standard or specification.

## 7 Calculation of test pressure

### 7.1 General

For material testing, the test pressure shall be calculated from a given circumferential hoop stress and based on the measured dimensions of the test piece, see 7.2.

For pipe testing, the test pressure shall be calculated from a given circumferential hoop stress and using one of the following options, given by the referring standard or specification:

- a) based on the measured dimensions of the test piece, see 7.2;
- b) based on the nominal dimensions of the test piece, see 7.3.

For testing of components, the test pressure shall be as given in the referring standard.

For testing of assemblies, the test pressure shall be calculated from a given circumferential hoop stress and based on the SDR of the pipe(s) used for the test piece, see 7.4, unless a test pressure is specified by the referring standard or specification.

## 7.2 Pressure calculations based on the measured dimensions of the test piece

Calculate the test pressure,  $p$ , in bar<sup>2)</sup>, to three significant figures, using the following equation:

$$p = 10 \sigma \frac{2e_{\min}}{d_{\text{em}} - e_{\min}}$$

where

$\sigma$  is the hoop stress to be induced by the applied pressure, in megapascals;

$d_{\text{em}}$  is the mean outside diameter of the test piece, in millimetres;

$e_{\min}$  is the minimum wall thickness of the free length of the test piece, in millimetres.

NOTE The factor 10 results from the ratio between megapascals and bar.

## 7.3 Pressure calculations based on the nominal dimensions of the test piece

Calculate the test pressure,  $p$ , in bar<sup>2)</sup>, to three significant figures, using the following equation:

$$p = 10 \sigma \frac{2e_n}{d_n - e_n}$$

where

$\sigma$  is the hoop stress to be induced by the applied pressure, in megapascals;

$d_n$  is the nominal outside diameter of the test piece, in millimetres;

$e_n$  is the nominal wall thickness of the free length of the test piece, in millimetres.

NOTE The factor 10 results from the ratio between megapascals and bar.

## 7.4 Pressure calculations based on SDR of pipe(s) of the test piece

Calculate the test pressure,  $p$ , in bar<sup>2)</sup>, to three significant figures, using the following equation:

$$p = \frac{2(10\sigma)}{[\text{SDR}] - 1}$$

where

$\sigma$  is the hoop stress to be induced by the applied pressure, in megapascals;

[SDR] is the standard dimension ratio of the pipe(s) of the test piece.

NOTE The factor 10 results from the ratio between megapascals and bar.

---

2) 1 bar = 0,1 MPa = 10<sup>5</sup> Pa; 1 MPa = 1 N/mm<sup>2</sup>.



## 8 Calibration and accuracy of the apparatus

The temperature and pressure control systems and the equipment for measuring temperature, pressure and time shall be capable of maintaining the values within the specified limits and shall be calibrated.

The accuracy of the apparatus shall be considered such that the requirements for temperature, pressure and time are fulfilled.

## 9 Conditioning

Prepare the test pieces, removing any traces of dirt, oil, wax or other contamination, and fit them with the end caps (5.1) specified for the test.

Measure and record the free length of the pipes of the test piece  $l_0$ , as appropriate.

Fill the test pieces with water, which may be preheated to a temperature not more than the test temperature.

After filling the test pieces, immerse them in a water bath or place them in an oven at the temperature specified by the referring standard and condition for a period in accordance with Table 1. When conditioning at temperatures in excess of 100 °C sufficient pressure shall be applied to prevent boiling.

**Table 1 — Conditioning periods**

Thickness $e_{\min}$ mm	Minimum conditioning period h
$e_{\min} < 3$	1
$3 \leq e_{\min} < 8$	3
$8 \leq e_{\min} < 16$	6
$16 \leq e_{\min} < 32$	10
$32 \leq e_{\min}$	16

NOTE It is recognized that extended conditioning periods beyond those specified in Table 1 could influence the test results.

Record the actual conditioning time.

The test pieces shall not be tested within the period of time after their manufacture specified in the referring standard. Otherwise, a minimum period of 24 h after production shall be observed.

## 10 Test procedure

**10.1** Select the type of test, i.e. “water-in-water”, “water-in-air”, or “water-in-liquid”, as specified by the referring standard or specification.

Measure and record the time taken to pressurize the test piece as follows.

Connect the test pieces to the pressurizing equipment (5.4) and bleed off the air. After conditioning, progressively and smoothly apply the test pressure as calculated in Clause 7, in the shortest time practicable between 30 s and 1 h depending upon the material, the size of the test piece and the capability of the pressurizing equipment.

When the test pressure is achieved, record the time or reset the timer as necessary to begin to measure the period for which the specified pressure is maintained in the test piece(s).

**10.2** Keep the test piece suspended in the thermally controlled environment. Maintain a constant temperature (see the referring standard or specification) and observe the temperature tolerances specified in 5.2 until testing ceases in accordance with 10.3 or 10.4 as applicable.

**10.3** The test is terminated either when the specified duration is reached, or when a failure or leak occurs in the test piece, in which case record the time to failure, unless the procedure given in 10.4 is applicable.

If a failure occurs, record the type, i.e. brittle, or ductile, or other.

**NOTE** Failure is "brittle" if no visible yield deformation has occurred in the failure zone. If the failure is accompanied by a yield deformation in the failure zone, visible without magnification, it is of the "ductile" type. For some materials, brittle failure could be indicated by weeping at the pipe surface.

In the event of equipment failure, tests which have been ongoing for a period of 500 h to 1 000 h may be continued providing the equipment is reinstated within one day. For tests which have been ongoing for a period of more than 1 000 h, the test may be continued, provided the equipment is reinstated within three days. The time during which the equipment is not able to function normally shall not be included in the test time. Test interruptions shall be recorded in the test report.

**10.4** If a break occurs in the test piece at a distance of less than  $0,1 l_0$  from an end cap, disregard the result and repeat the test using another test piece [ $l_0$  is the free length of the pipe(s) of the test piece, see ISO 1167-2 or ISO 1167-4].

When testing components, if there is a leakage outside of the component itself (failure of the seal or bursting of the pipe), or any failure associated with grooves machined and indicative of inappropriate groove design and/or machining conditions, repeat the test — if necessary using other components — such that the assembly remains watertight for the minimum period required for the test.

## 11 Test report

The test report shall include the following information:

- a) a reference to this and other relevant parts of ISO 1167;
- b) the complete identification of the sample;
- c) type of the material or materials of each component of the test piece;
- d) the nominal dimension of each component of the test piece;
- e) the measured dimensions, e.g. minimum wall thickness, of each component of the test piece and free length of the pipe(s), as appropriate;
- f) the conditions of preparation of test pieces (e.g. conditions of fusion); for injection-moulded test pieces: details of any conditioning of the material before moulding, of the injection-moulding machine used and of the moulding conditions, as appropriate;
- g) the test temperature and accuracy of its measurement;
- h) the stress applied and/or the applied test pressure;
- i) the nature of the environment (air, water or liquid and, in the case of the latter, the liquid used);
- j) the type of end cap (see 5.1) and, in the case of components, the type of pressure-tight device;

- k) the number of test pieces tested;
- l) the conditioning time (see Clause 9) and, if required, the time taken to pressurize the test piece (see 10.1);
- m) the test duration at the test pressure (see 10.1 and 10.3);
- n) in the event of failure, the type of failure;
- o) the observations made during and after the test;
- p) any factors that could have affected the results, such as any incidents, test interruptions or any operating details not specified in this part of ISO 1167;
- q) identification of the test unit;
- r) the date of the test or dates between which the test was conducted.





## BSI — British Standards Institution

BSI is the independent national body responsible for preparing British Standards. It presents the UK view on standards in Europe and at the international level. It is incorporated by Royal Charter.

### Revisions

British Standards are updated by amendment or revision. Users of British Standards should make sure that they possess the latest amendments or editions.

It is the constant aim of BSI to improve the quality of our products and services. We would be grateful if anyone finding an inaccuracy or ambiguity while using this British Standard would inform the Secretary of the technical committee responsible, the identity of which can be found on the inside front cover.  
Tel: +44 (0)20 8996 9000. Fax: +44 (0)20 8996 7400.

BSI offers members an individual updating service called PLUS which ensures that subscribers automatically receive the latest editions of standards.

### Buying standards

Orders for all BSI, international and foreign standards publications should be addressed to Customer Services. Tel: +44 (0)20 8996 9001.  
Fax: +44 (0)20 8996 7001. Email: [orders@bsi-global.com](mailto:orders@bsi-global.com). Standards are also available from the BSI website at <http://www.bsi-global.com>.

In response to orders for international standards, it is BSI policy to supply the BSI implementation of those that have been published as British Standards, unless otherwise requested.

### Information on standards

BSI provides a wide range of information on national, European and international standards through its Library and its Technical Help to Exporters Service. Various BSI electronic information services are also available which give details on all its products and services. Contact the Information Centre.  
Tel: +44 (0)20 8996 7111. Fax: +44 (0)20 8996 7048. Email: [info@bsi-global.com](mailto:info@bsi-global.com).

Subscribing members of BSI are kept up to date with standards developments and receive substantial discounts on the purchase price of standards. For details of these and other benefits contact Membership Administration.  
Tel: +44 (0)20 8996 7002. Fax: +44 (0)20 8996 7001.  
Email: [membership@bsi-global.com](mailto:membership@bsi-global.com).

Information regarding online access to British Standards via British Standards Online can be found at <http://www.bsi-global.com/bsonline>.

Further information about BSI is available on the BSI website at <http://www.bsi-global.com>.

### Copyright

Copyright subsists in all BSI publications. BSI also holds the copyright, in the UK, of the publications of the international standardization bodies. Except as permitted under the Copyright, Designs and Patents Act 1988 no extract may be reproduced, stored in a retrieval system or transmitted in any form or by any means – electronic, photocopying, recording or otherwise – without prior written permission from BSI.

This does not preclude the free use, in the course of implementing the standard, of necessary details such as symbols, and size, type or grade designations. If these details are to be used for any other purpose than implementation then the prior written permission of BSI must be obtained.

Details and advice can be obtained from the Copyright & Licensing Manager.  
Tel: +44 (0)20 8996 7070. Fax: +44 (0)20 8996 7553.  
Email: [copyright@bsi-global.com](mailto:copyright@bsi-global.com).

BSI  
389 Chiswick High Road  
London  
W4 4AL