

Polyolefin pipes for the conveyance of fluids — Determination of resistance to crack propagation — Test method for slow crack growth on notched pipes (ISO 13479:2009)

MAHCO

ICS 23.040.20

National foreword

This British Standard is the UK implementation of EN ISO 13479:2009. It supersedes BS EN ISO 13479:1997 which is withdrawn.

The UK participation in its preparation was entrusted to Technical Committee PRI/88/4, Test methods.

A list of organizations represented on this committee can be obtained on request to its secretary.

This publication does not purport to include all the necessary provisions of a contract. Users are responsible for its correct application.

Compliance with a British Standard cannot confer immunity from legal obligations.



This British Standard was published under the authority of the Standards Policy and Strategy Committee on 30 November 2009.

© BSI 2009

ISBN 978 0 580 63079 8

Amendments/corrigenda issued since publication

Date	Comments

English Version

Polyolefin pipes for the conveyance of fluids - Determination of resistance to crack propagation - Test method for slow crack growth on notched pipes (ISO 13479:2009)

Tubes en polyoléfines pour le transport des fluides - Détermination de la résistance à la propagation de la fissure - Méthode d'essai de la propagation lente de la fissure d'un tube entaillé (essai d'entaille) (ISO 13479:2009)

Rohre aus Polyolefinen für den Transport von Fluiden - Bestimmung des Widerstandes gegen Rißfortpflanzung - Prüfverfahren für langsames Rißwachstum an gekerbten Rohren (Kerbprüfung) (ISO 13479:2009)

This European Standard was approved by CEN on 19 August 2009.

CEN members are bound to comply with the CEN/CENELEC Internal Regulations which stipulate the conditions for giving this European Standard the status of a national standard without any alteration. Up-to-date lists and bibliographical references concerning such national standards may be obtained on application to the CEN Management Centre or to any CEN member.

This European Standard exists in three official versions (English, French, German). A version in any other language made by translation under the responsibility of a CEN member into its own language and notified to the CEN Management Centre has the same status as the official versions.

CEN members are the national standards bodies of Austria, Belgium, Bulgaria, Cyprus, Czech Republic, Denmark, Estonia, Finland, France, Germany, Greece, Hungary, Iceland, Ireland, Italy, Latvia, Lithuania, Luxembourg, Malta, Netherlands, Norway, Poland, Portugal, Romania, Slovakia, Slovenia, Spain, Sweden, Switzerland and United Kingdom.



EUROPEAN COMMITTEE FOR STANDARDIZATION
COMITÉ EUROPÉEN DE NORMALISATION
EUROPÄISCHES KOMITEE FÜR NORMUNG

Management Centre: Avenue Marnix 17, B-1000 Brussels

Foreword

This document (EN ISO 13479:2009) has been prepared by Technical Committee ISO/TC 138 "Plastics pipes, fittings and valves for the transport of fluids" in collaboration with Technical Committee CEN/TC 155 "Plastics piping systems and ducting systems" the secretariat of which is held by NEN.

This European Standard shall be given the status of a national standard, either by publication of an identical text or by endorsement, at the latest by March 2010, and conflicting national standards shall be withdrawn at the latest by March 2010.

Attention is drawn to the possibility that some of the elements of this document may be the subject of patent rights. CEN [and/or CENELEC] shall not be held responsible for identifying any or all such patent rights.

This document supersedes EN ISO 13479:1997.

According to the CEN/CENELEC Internal Regulations, the national standards organizations of the following countries are bound to implement this European Standard: Austria, Belgium, Bulgaria, Cyprus, Czech Republic, Denmark, Estonia, Finland, France, Germany, Greece, Hungary, Iceland, Ireland, Italy, Latvia, Lithuania, Luxembourg, Malta, Netherlands, Norway, Poland, Portugal, Romania, Slovakia, Slovenia, Spain, Sweden, Switzerland and the United Kingdom.

Endorsement notice

The text of ISO 13479:2009 has been approved by CEN as a EN ISO 13479:2009 without any modification.

A large, light blue watermark logo is centered on the page. It consists of a stylized, abstract shape above the word "MAHCO" in a bold, sans-serif font.

MAHCO

Foreword

ISO (the International Organization for Standardization) is a worldwide federation of national standards bodies (ISO member bodies). The work of preparing International Standards is normally carried out through ISO technical committees. Each member body interested in a subject for which a technical committee has been established has the right to be represented on that committee. International organizations, governmental and non-governmental, in liaison with ISO, also take part in the work. ISO collaborates closely with the International Electrotechnical Commission (IEC) on all matters of electrotechnical standardization.

International Standards are drafted in accordance with the rules given in the ISO/IEC Directives, Part 2.

The main task of technical committees is to prepare International Standards. Draft International Standards adopted by the technical committees are circulated to the member bodies for voting. Publication as an International Standard requires approval by at least 75 % of the member bodies casting a vote.

Attention is drawn to the possibility that some of the elements of this document may be the subject of patent rights. ISO shall not be held responsible for identifying any or all such patent rights.

ISO 13479 was prepared by Technical Committee ISO/TC 138, *Plastics pipes, fittings and valves for the transport of fluids*, Subcommittee SC 5, *General properties of pipes, fittings and valves of plastic materials and their accessories — Test methods and basic specifications*.

This second edition cancels and replaces the first edition (ISO 13479:1997), which has been technically revised.

MAHCO



Polyolefin pipes for the conveyance of fluids — Determination of resistance to crack propagation — Test method for slow crack growth on notched pipes

1 Scope

This International Standard specifies a test method for determining the resistance to slow crack growth of polyolefin pipes, expressed in terms of time to failure in a hydrostatic pressure test on a pipe with machined longitudinal notches in the outside surface. The test is applicable to pipes of wall thickness greater than 5 mm.

2 Normative references

The following referenced documents are indispensable for the application of this document. For dated references, only the edition cited applies. For undated references, the latest edition of the referenced document (including any amendments) applies.

ISO 161-1, *Thermoplastics pipes for the conveyance of fluids — Nominal outside diameters and nominal pressures — Part 1: Metric series*

ISO 1167-1, *Thermoplastics pipes, fittings and assemblies for the conveyance of fluids — Determination of the resistance to internal pressure — Part 1: General method*

ISO 1167-2, *Thermoplastics pipes, fittings and assemblies for the conveyance of fluids — Determination of the resistance to internal pressure — Part 2: Preparation of pipe test pieces*

ISO 3126, *Plastics piping systems — Plastics components — Determination of dimensions*

ISO 6108, *Double equal angle cutters with plain bore and key drive*

ISO 11922-1, *Thermoplastics pipes for the conveyance of fluids — Dimensions and tolerances — Part 1: Metric series*

3 Terms and definitions

For the purposes of this document, the terms and definitions given in ISO 161-1 and ISO 11922-1 apply.

4 Principle

Lengths of pipe with four machined longitudinal external notches are subject to a hydrostatic pressure test whilst immersed in a water tank at 80 °C in accordance with ISO 1167-1 and ISO 1167-2. The time to failure or test period is recorded.

NOTE It is assumed that the following test parameters are set by the standard or specification making reference to this International Standard:

- a) the number of test pieces, if applicable (see 6.5);
- b) the test pressure (see 8.1);
- c) the test period (see 8.1).

5 Apparatus

5.1 Pipe pressure-testing equipment, as specified in ISO 1167-1.

5.2 Notch-machining equipment, i.e. a milling machine with a horizontal mandrel rigidly fixed to the bed to enable the pipe to be securely clamped to give a straight test piece.

The mandrel shall support the pipe bore beneath and along the full length of the notch to be machined.

The milling cutter mounted on a horizontal arbor shall be a 60° included-angle V-cutter conforming to ISO 6108, having a cutting rate of $(0,010 \pm 0,002)$ (mm/r)/tooth (see example).

EXAMPLE A cutter with 20 teeth rotating at 700 r/min, traversed at a speed of 150 mm/min, has a cutting rate of $150/(20 \times 700) = 0,011$ (mm/r)/tooth.

The milling cutter shall be carefully protected against damage. The cutter shall be subject to a running-in treatment amounting to 10 m of notching prior to its first use for the preparation of test pieces. It shall not be used for any other material or purpose and shall be replaced after 500 m of notching.

The cutter shall be checked for damage or wear after each 100 m of cutting. The cutter teeth shall be compared with a new cutter by examination with a microscope using a magnification of 10 to 20 times. If there is any evidence of damage or wear it shall be replaced.

6 Test piece preparation

6.1 General

Prior to any measurements the test piece shall be conditioned at (23 ± 2) °C for at least 4 h.

6.2 Test pieces

Each test piece shall comprise a length of pipe sufficient to give a minimum free length of pipe of $(3d_n \pm 5)$ mm between the end caps, when fitted for pressure testing in accordance with ISO 1167-2, where d_n is the nominal outside diameter of the pipe. For pipes with a nominal outside diameter $d_n > 315$ mm, a minimum free length of $(3d_n \pm 5)$ mm shall be used where practicable; otherwise, a minimum free length of greater than or equal to 1 000 mm shall be used. Type A end caps in accordance with ISO 1167-1 shall be used.

NOTE The use of pipes less than $(3d_n \pm 5)$ mm and notch lengths of less than the nominal outside diameter is subject to further study.

6.3 Notch location and measurement of dimensions

Positions shall be marked for machining four notches equally spaced around the pipe circumference (see Figure 1). Measure the mean outside diameter, d_{em} , of the test pipe and the wall thickness of the pipe in the centre of the pipe at each notch position in accordance with ISO 3126.

6.4 Machining the notches

6.4.1 If the wall thickness of the test piece is greater than 50 mm, the material shall be machined with a slot drill of 15 mm to 20 mm diameter to leave approximately 10 mm to be removed by the V-cutter, used in accordance with 6.4.2.

6.4.2 Each notch shall be machined by climb milling (see Figure 2) to such a depth as to produce a pipe wall ligament thickness of between 0,78 and 0,82 times the minimum wall thickness, as specified in ISO 11922-1, for the diameter and pressure series of the pipe as shown in Table A.1 (see Note in this subclause). The ends of each notch shall be aligned circumferentially as shown in Figure 1 and Figure 2.

The length of each notch, at full depth, shall be equal to the pipe nominal outside diameter ± 1 mm. For pipes greater than 315 mm in diameter with a free length of pipe of less than $(3 d_n \pm 5)$ mm, the length of each notch, at full depth, shall be equal to the free length minus (500 ± 1) mm, in accordance with 6.2.

NOTE To achieve a remaining ligament within the required tolerance range, it is advisable to aim for a remaining ligament at the maximum of the tolerance range. This is because the pipe wall can move due to the release of residual stresses, resulting in a deeper than anticipated notch.

6.4.3 Measure and record the depth of each notch and the ligament thickness, δ_{lg} .

NOTE 1 Measurement can be facilitated through the use of a dial gauge with a narrow angle tip mounted in a V-block.

NOTE 2 When difficulty is encountered in measuring the ligament thickness of thick walled pipe, reference is made to the method specified in 8.2.

6.4.4 The test piece shall have end caps fitted, which ensure that any longitudinal internal pressure load will act fully on the pipe (e.g. as shown for the type A arrangement in ISO 1167-2).

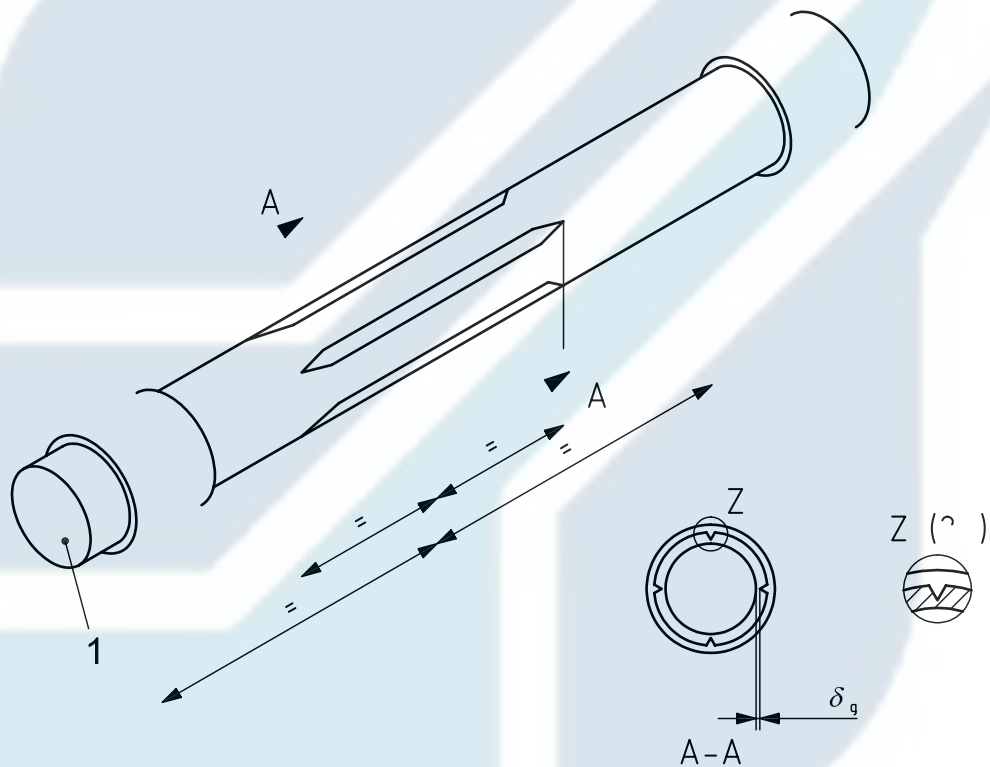

Key

1 end cap

δ_{lg} ligament thickness: 0,78 to 0,82 times minimum ISO wall thickness, in millimetres

Figure 1 — Pipe test piece

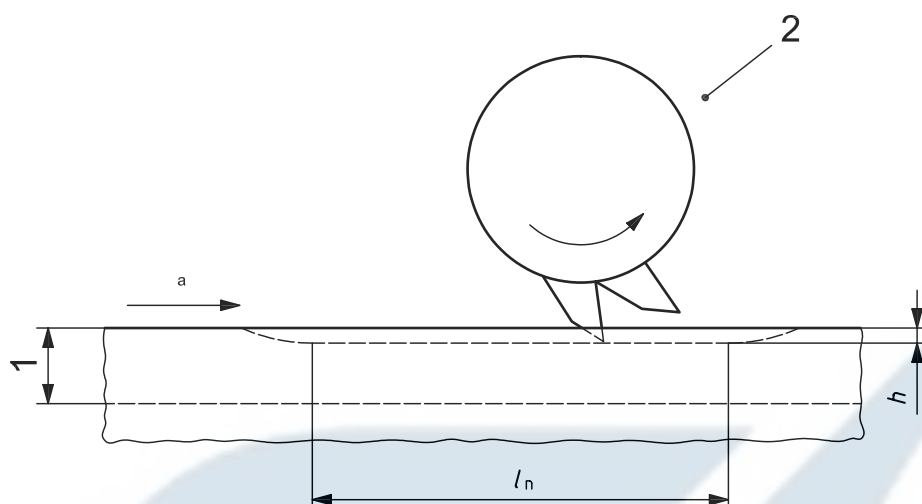

Key

- 1 pipe wall
- 2 60° double equal angle cutter
- h notch depth, in millimetres
- l_n notch length ($1 \times d_n$) centred on test piece
- a Direction.

Figure 2 — Notching method

6.5 Number of test pieces

Prepare a minimum of three test pieces, unless specified otherwise in the referring standard.

7 Conditioning

The test pieces shall be filled with water, immersed in a water tank at 80 °C and allowed to condition in accordance with the conditioning time stated in ISO 1167-1 for the pipe wall thickness.

8 Procedure

8.1 Hydrostatic-pressure testing

8.1.1 Pressurize the test piece with water in accordance with ISO 1167-1 at a test temperature of 80 °C, applying and maintaining the pressure specified by the referring standard.

8.1.2 Connect the test piece(s) to the pressurizing equipment and bleed off the air. After conditioning in accordance with Clause 7, progressively and smoothly apply the test pressure, in the shortest time practicable between 30 s and 1 h, depending upon the size of the test piece and the capability of the pressurizing equipment.

8.1.3 Maintain the pressure until either the test piece ruptures or the time specified by the referring standard has elapsed, whichever occurs first. Record the time under pressure to the nearest hour. In the case of failure, record the location of the failure for each test piece.

NOTE Table B.1 gives applicable pressure levels, dependent on material type and pipe series.

8.2 Ligament thickness measurement after testing

Measurement after testing should be carried out if premature failure has occurred. The following method is recommended.

On completion of the pressure test, remove the test piece from the water tank and allow to cool to ambient temperature. Cut a section of pipe out from around the position of each notch. Open up the notch to give clear access to one of the machined surfaces of the notch. Measure the width of the machined surface of the notch, b_s , to an accuracy $\pm 0,1$ mm with a microscope or equivalent means, as shown in Figure 3. If required by the referring standard, measure the depth of penetration of the crack.

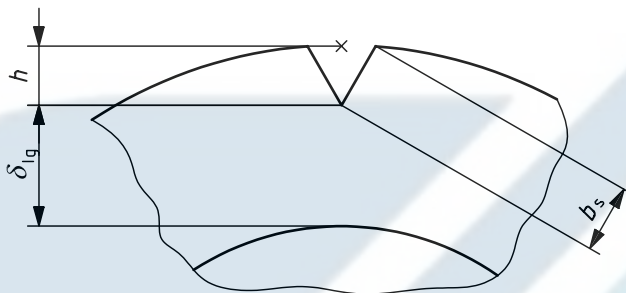

Key

b_s width of machined surface of notch

h notch depth

δ_{lg} ligament thickness

Figure 3 — Measurement to calculate notch depth

Calculate the notch depth, h , in millimetres, using the Equation (1):

$$h = 0,5 \left[d_{em} - \sqrt{(d_{em}^2 - b_s^2)} \right] + 0,866 b_s \quad (1)$$

where

b_s is the width of machined surface of the notch, in millimetres;

d_{em} is the measured mean pipe outside diameter, in millimetres.

Calculate the ligament thickness, δ_{lg} , from the notch depth and the individual average wall thickness alongside each notch position. Record the values obtained.

9 Test report

The test report shall include the following information:

- reference to this International Standard, i.e. ISO 13479:2009 and to the referring standard or specification;
- all details necessary for complete identification of the pipe (manufacturer, type of pipe and production date);
- the cutter size and number of teeth;
- the cutter speed, in revolutions per minute and the traverse speed, in millimetres per minute;

- e) the mean pipe outside diameter, in millimetres, and the pipe series or SDR;
- f) the notch depth and ligament thickness for each notch;
- g) the location of any failed notch;
- h) the test pressure;
- i) the time under pressure or the time to failure, in hours, as applicable;
- j) the details of any factors which could have affected the results, such as any incidents or any operations not specified in this International Standard;
- k) the date of the test.



Annex A
(normative)

Ligament thicknesses



Table A.1 — Remaining ligament thicknesses for pipe series

Dimensions in millimetres

Nominal outside diameter	SDR6 S2,5		SDR7,4 S3,2		SDR9 S4		SDR11 S5		SDR13,6 S6,3		SDR17 S8		SDR17,6 S8,3		SDR21 S10		SDR26 S12,5		SDR33 S16		SDR41 S20	
	Ligament thickness, δ_{lg}																					
d_n	min.	max.	min.	max.	min.	max.	min.	max.	min.	max.	min.	max.	min.	max.	min.	max.	min.	max.	min.	max.	min.	max.
32	4,2	4,4																				
40	5,2	5,5	4,3	4,5																		
50	6,5	6,8	5,4	5,7	4,4	4,6																
63	8,2	8,6	6,7	7,1	5,5	5,8	4,5	4,8														
75	9,8	10,3	8,0	8,4	6,5	6,9	5,3	5,6	4,3	4,5												
90	11,7	12,3	9,6	10,1	7,9	8,3	6,4	6,7	5,1	5,4	4,2	4,4	4,0	4,2								
110	14,3	15,0	11,8	12,4	9,6	10,1	7,8	8,2	6,3	6,6	5,1	5,4	4,9	5,2	4,1	4,3						
125	16,2	17,1	13,3	14,0	10,9	11,5	8,9	9,3	7,2	7,5	5,8	6,1	5,5	5,8	4,7	4,9						
140	18,2	19,1	15,0	15,7	12,2	12,9	9,9	10,4	8,0	8,4	6,5	6,8	6,2	6,6	5,2	5,5	4,2	4,4				
160	20,7	21,8	17,1	18,0	14,0	14,7	11,4	12,0	9,2	9,7	7,4	7,8	7,1	7,5	6,0	6,3	4,8	5,1				
180	23,3	24,5	19,2	20,2	15,7	16,5	12,8	13,4	10,4	10,9	8,3	8,8	8,0	8,4	6,7	7,1	5,4	5,7	4,3	4,5		
200	25,9	27,2	21,4	22,5	17,5	18,4	14,2	14,9	11,5	12,1	9,3	9,8	8,9	9,3	7,5	7,9	6,0	6,3	4,8	5,1		
225	29,2	30,7	24,0	25,3	19,6	20,6	16,0	16,8	12,9	13,6	10,5	11,0	10,0	10,5	8,4	8,9	6,7	7,1	5,4	5,7	4,3	4,5
250	32,4	34,0	26,7	28,0	21,8	22,9	17,7	18,6	14,4	15,1	11,5	12,1	11,1	11,6	9,3	9,8	7,5	7,9	6,0	6,3	4,8	5,0
280	36,3	38,1	29,9	31,4	24,3	25,6	19,8	20,8	16,1	16,9	12,9	13,6	12,4	13,0	10,5	11,0	8,3	8,8	6,7	7,1	5,4	5,7
315	40,8	42,9	33,6	35,3	27,3	28,7	22,3	23,5	18,2	19,1	14,6	15,3	14,0	14,7	11,7	12,3	9,4	9,9	7,6	8,0	6,0	6,3
355	46,0	48,4	37,8	39,8	30,8	32,4	25,2	26,5	20,4	21,4	16,5	17,3	15,8	16,6	13,2	13,9	10,6	11,2	8,5	8,9	6,8	7,1
400			42,7	44,9	34,7	36,5	28,4	29,8	22,9	24,1	18,5	19,4	17,8	18,7	14,9	15,7	11,9	12,5	9,6	10,1	7,6	8,0
450			48,1	50,6	39,0	41,0	31,9	33,5	25,8	27,1	20,8	21,9	19,9	21,0	16,8	17,6	13,4	14,1	10,8	11,3	8,6	9,0
500					43,4	45,6	35,5	37,3	28,7	30,2	23,1	24,3	22,2	23,3	18,6	19,6	14,9	15,7	11,9	12,5	9,5	10,0
560							39,7	41,7	32,1	33,8	25,9	27,2	24,9	26,2	20,8	21,9	16,7	17,5	13,4	14,1	10,7	11,2
630							44,7	47,0	36,2	38,0	29,1	30,6	27,9	29,4	23,4	24,6	18,8	19,8	15,1	15,8	12,0	12,6
710									40,8	42,9	32,8	34,5	31,4	33,0	26,4	27,8	21,2	22,3	17,0	17,9	13,6	14,3
800									45,9	48,3	37,0	38,9	35,3	37,1	29,7	31,2	23,9	25,1	19,1	20,1	15,3	16,1
900											41,7	43,9	39,8	41,8	33,5	35,2	27,1	28,5	21,5	22,6	17,2	18,0
1 000											46,3	48,6	44,1	46,4	37,2	39,1	30,0	31,6	23,9	25,1	19,0	20,0
1 200															44,6	46,9	36,0	37,9	28,4	29,8	22,8	24,0
1 400																	42,0	44,2	33,1	34,8	26,7	28,0
1 600																	48,0	50,4	37,8	39,8	30,5	32,1

Annex B (normative)

Test-pressure levels for polyethylene

NOTE It is possible that the test is applicable to other thermoplastics, but test parameters would need to be developed.

For a notch test for slow crack growth in polyethylene (PE) pipe, at the test temperature of 80 °C the applicable pressure levels depend on the material type and pipe series of test pipe as given in Table B.1.

Table B.1 — Test-pressure levels

Standard dimension ratio (SDR)	S series	Test pressure, p bar	
		PE 80	PE 100
41	20	2	2,3
33	16	2,5	2,88
26	12,5	3,2	3,68
21	10	4	4,6
17,6	8,3	4,82	5,54
17	8	5	5,75
13,6	6,3	6,35	7,3
11	5	8	9,2
9	4	10	11,5
7,4	3,2	12,5	14,38
6	2,5	16	18,4

NOTE These pressure levels are calculated to give nominal plain-pipe hydrostatic stress levels of 4,0 MPa in PE 80 materials and 4,6 MPa in PE 100 materials using Equation (B.1):

$$p = \frac{10\sigma}{S} \text{ or } p = \frac{20\sigma}{\text{SDR} - 1} \quad (\text{B.1})$$

where

- σ is the hydrostatic stress, in megapascals;
- S is the pipe series;
- SDR is the standard dimension ratio.

BSI - British Standards Institution

BSI is the independent national body responsible for preparing British Standards. It presents the UK view on standards in Europe and at the international level. It is incorporated by Royal Charter.

Revisions

British Standards are updated by amendment or revision. Users of British Standards should make sure that they possess the latest amendments or editions.

It is the constant aim of BSI to improve the quality of our products and services. We would be grateful if anyone finding an inaccuracy or ambiguity while using this British Standard would inform the Secretary of the technical committee responsible, the identity of which can be found on the inside front cover. Tel: +44 (0)20 8996 9000. Fax: +44 (0)20 8996 7400.

BSI offers members an individual updating service called PLUS which ensures that subscribers automatically receive the latest editions of standards.

Buying standards

Orders for all BSI, international and foreign standards publications should be addressed to Customer Services. Tel: +44 (0)20 8996 9001. Fax: +44 (0)20 8996 7001 Email: orders@bsigroup.com You may also buy directly using a debit/credit card from the BSI Shop on the Website <http://www.bsigroup.com/shop>

In response to orders for international standards, it is BSI policy to supply the BSI implementation of those that have been published as British Standards, unless otherwise requested.

Information on standards

BSI provides a wide range of information on national, European and international standards through its Library and its Technical Help to Exporters Service. Various BSI electronic information services are also available which give details on all its products and services. Contact Information Centre. Tel: +44 (0)20 8996 7111 Fax: +44 (0)20 8996 7048 Email: info@bsigroup.com

Subscribing members of BSI are kept up to date with standards developments and receive substantial discounts on the purchase price of standards. For details of these and other benefits contact Membership Administration. Tel: +44 (0)20 8996 7002 Fax: +44 (0)20 8996 7001 Email: membership@bsigroup.com

Information regarding online access to British Standards via British Standards Online can be found at <http://www.bsigroup.com/BSOL>

Further information about BSI is available on the BSI website at <http://www.bsigroup.com>.

Copyright

Copyright subsists in all BSI publications. BSI also holds the copyright, in the UK, of the publications of the international standardization bodies. Except as permitted under the Copyright, Designs and Patents Act 1988 no extract may be reproduced, stored in a retrieval system or transmitted in any form or by any means – electronic, photocopying, recording or otherwise – without prior written permission from BSI.

This does not preclude the free use, in the course of implementing the standard, of necessary details such as symbols, and size, type or grade designations. If these details are to be used for any other purpose than implementation then the prior written permission of BSI must be obtained.

Details and advice can be obtained from the Copyright and Licensing Manager. Tel: +44 (0)20 8996 7070 Email: copyright@bsigroup.com