**Plastics — Determination of the melt
mass-flow rate (MFR) and the melt
volume-flow rate (MVR) of thermoplastics**

*Plastiques — Détermination de l'indice de fluidité à chaud des
thermoplastiques, en masse (MFR) et en volume (MVR)*

MAHCO

MEHR AB HAYAT SANAAT KERMAN
www.MAHCOpipe.com



Reference number
ISO 1133:2005(E)

© ISO 2005

PDF disclaimer

This PDF file may contain embedded typefaces. In accordance with Adobe's licensing policy, this file may be printed or viewed but shall not be edited unless the typefaces which are embedded are licensed to and installed on the computer performing the editing. In downloading this file, parties accept therein the responsibility of not infringing Adobe's licensing policy. The ISO Central Secretariat accepts no liability in this area.

Adobe is a trademark of Adobe Systems Incorporated.

Details of the software products used to create this PDF file can be found in the General Info relative to the file; the PDF-creation parameters were optimized for printing. Every care has been taken to ensure that the file is suitable for use by ISO member bodies. In the unlikely event that a problem relating to it is found, please inform the Central Secretariat at the address given below.



© ISO 2005

All rights reserved. Unless otherwise specified, no part of this publication may be reproduced or utilized in any form or by any means, electronic or mechanical, including photocopying and microfilm, without permission in writing from either ISO at the address below or ISO's member body in the country of the requester.

ISO copyright office
Case postale 56 • CH-1211 Geneva 20
Tel. + 41 22 749 01 11
Fax + 41 22 749 09 47
E-mail copyright@iso.org
Web www.iso.org

Published in Switzerland

MEHR AB HAYAT SANAAT KERMAN
www.MAHCOpipe.com

Contents

Page

Foreword.....	iv
1 Scope	1
2 Normative references	1
3 Terms and definitions	2
4 Principle	3
5 Apparatus	3
5.1 Extrusion plastometer	3
5.2 Accessory equipment	6
6 Test sample	7
6.1 Sample form	7
6.2 Conditioning	7
7 Temperature-calibration, cleaning and maintenance of the apparatus	7
7.1 Calibration of the temperature-control system	7
7.2 Cleaning the apparatus	8
8 Procedure A: mass-measurement method	8
8.1 Selection of temperature and load	8
8.2 Cleaning	8
8.3 Selection of sample mass and charging cylinder	8
8.4 Measurements	9
8.5 Expression of results	10
9 Procedure B: displacement-measurement method	10
9.1 Selection of temperature and load	10
9.2 Minimum piston displacement distance	10
9.3 Timer	11
9.4 Preparation for the test	11
9.5 Measurements	11
9.6 Expression of results	11
10 Flow rate ratio (FRR)	12
11 Precision	12
12 Test report	13
Annex A (normative) Test conditions for MFR and MVR determinations	14
Annex B (informative) Conditions specified in International Standards for the determination of the melt flow rate of thermoplastic materials	15

MAHCO

Foreword

ISO (the International Organization for Standardization) is a worldwide federation of national standards bodies (ISO member bodies). The work of preparing International Standards is normally carried out through ISO technical committees. Each member body interested in a subject for which a technical committee has been established has the right to be represented on that committee. International organizations, governmental and non-governmental, in liaison with ISO, also take part in the work. ISO collaborates closely with the International Electrotechnical Commission (IEC) on all matters of electrotechnical standardization.

International Standards are drafted in accordance with the rules given in the ISO/IEC Directives, Part 2.

The main task of technical committees is to prepare International Standards. Draft International Standards adopted by the technical committees are circulated to the member bodies for voting. Publication as an International Standard requires approval by at least 75 % of the member bodies casting a vote.

Attention is drawn to the possibility that some of the elements of this document may be the subject of patent rights. ISO shall not be held responsible for identifying any or all such patent rights.

ISO 1133 was prepared by Technical Committee ISO/TC 61, *Plastics*, Subcommittee SC 5, *Physical-chemical properties*.

This fourth edition cancels and replaces the third edition (ISO 1133:1997), in which the clauses relating to temperature control have been revised. In addition, the clarity of the text has been improved.

MAHCO

Plastics — Determination of the melt mass-flow rate (MFR) and the melt volume-flow rate (MVR) of thermoplastics

1 Scope

This International Standard specifies two procedures for the determination of the melt mass-flow rate (MFR) and the melt volume-flow rate (MVR) of thermoplastic materials under specified conditions of temperature and load. Procedure A is a mass-measurement method. Procedure B is a displacement-measurement method. Normally, the test conditions for measurement of melt flow rate are specified in the material standard with a reference to this International Standard. The test conditions normally used for thermoplastics are listed in Annexes A and B.

The MVR will be found particularly useful when comparing materials of different filler content and when comparing filled with unfilled thermoplastics. The MFR can be determined from MVR measurements provided the melt density at the test temperature and pressure is known.

These methods are in principle also applicable to thermoplastics for which the rheological behaviour is affected during the measurement by phenomena such as hydrolysis, condensation or crosslinking, but only if the effect is limited in extent and only if the repeatability and reproducibility are within an acceptable range. For materials which show significantly affected rheological behaviour during testing, these methods are not appropriate. In such cases, the use of the viscosity number in dilute solution, determined in accordance with the relevant part of ISO 1628, is recommended for characterization purposes.

NOTE The rates of shear in these methods are much smaller than those used under normal conditions of processing, and therefore data obtained by these methods for various thermoplastics may not always correlate with their behaviour during processing. Both methods are used primarily in quality control.

2 Normative references

The following referenced documents are indispensable for the application of this document. For dated references, only the edition cited applies. For undated references, the latest edition of the referenced document (including any amendments) applies.

ISO 1622-2, *Plastics — Polystyrene (PS) moulding and extrusion materials — Part 2: Preparation of test specimens and determination of properties*

ISO 1628 (all parts), *Plastics — Determination of the viscosity of polymers in dilute solution using capillary viscometers*

ISO 1872-2, *Plastics — Polyethylene (PE) moulding and extrusion materials — Part 2: Preparation of test specimens and determination of properties*

ISO 1873-2, *Plastics — Polypropylene (PP) moulding and extrusion materials — Part 2: Preparation of test specimens and determination of properties*

ISO 2580-2, *Plastics — Acrylonitrile-butadiene-styrene (ABS) moulding and extrusion materials — Part 2: Preparation of test specimens and determination of properties*

ISO 1133:2005(E)

ISO 2897-2, *Plastics — Impact-resistant polystyrene (PS-I) moulding and extrusion materials — Part 2: Preparation of test specimens and determination of properties*

ISO 4287, *Geometrical Product Specifications (GPS) — Surface texture: Profile method — Terms, definitions and surface texture parameters*

ISO 4613-2, *Plastics — Ethylene/vinyl acetate (E/VAC) moulding and extrusion materials — Part 2: Preparation of test specimens and determination of properties*

ISO 4894-2, *Plastics — Styrene/acrylonitrile (SAN) moulding and extrusion materials — Part 2: Preparation of test specimens and determination of properties*

ISO 6402-2, *Plastics — Acrylonitrile-styrene-acrylate (ASA), acrylonitrile-(ethylene-propylene-diene)-styrene (AEPDS) and acrylonitrile-(chlorinated polyethylene)-styrene (ACS) moulding and extrusion materials — Part 2: Preparation of test specimens and determination of properties*

ISO 6507-1, *Metallic materials — Vickers hardness test — Part 1: Test method*

ISO 7391-2, *Plastics — Polycarbonate (PC) moulding and extrusion materials — Part 2: Preparation of test specimens and determination of properties*

ISO 8257-2, *Plastics — Poly(methyl methacrylate) (PMMA) moulding and extrusion materials — Part 2: Preparation of test specimens and determination of properties*

ISO 8986-2, *Plastics — Polybutene (PB) moulding and extrusion materials — Part 2: Preparation of test specimens and determination of properties*

ISO 9988-2, *Plastics — Polyoxymethylene (POM) moulding and extrusion materials — Part 2: Preparation of test specimens and determination of properties*

ISO 10366-2, *Plastics — Methyl methacrylate-acrylonitrile-butadiene-styrene (MABS) moulding and extrusion materials — Part 2: Preparation of test specimens and determination of properties*

ISO 15494, *Plastic piping systems for industrial applications — Polybutene (PB), polyethylene (PE) and polypropylene (PP) — Specifications for components and the system — Metric series*

ISO 15876-3, *Plastics piping systems for hot and cold water installations — Polybutylene (PB) — Part 3: Fittings*

3 Terms and definitions

For the purpose of this document, the following terms and definitions apply.

3.1

melt mass-flow rate

MFR

rate of extrusion of a molten resin through a die of specified length and diameter under prescribed conditions of temperature, load and piston position in the barrel of an extrusion plastometer, the rate being determined as the mass extruded over a specified time

NOTE The correct SI units are decigrams per minute (dg/min). However, grams per 10 minutes (g/10 min) have customarily been used in the past and are also acceptable.

3.2**melt volume-flow rate****MVR**

rate of extrusion of a molten resin through a die of specified length and diameter under prescribed conditions of temperature, load and piston position in the barrel of an extrusion plastometer, the rate being determined as the volume extruded over a specified time

NOTE The correct SI units are cubic decimetres per minute (dm^3/min). More commonly used units, which are also acceptable, are cubic centimetres per 10 minutes ($\text{cm}^3/10 \text{ min}$).

3.3**load**

combined mass of piston and added weight, as specified by the conditions of the test

NOTE It is expressed in kilograms (kg).

4 Principle

The melt mass-flow rate (MFR) and the melt volume-flow rate (MVR) are determined by extruding molten material from the barrel of a plastometer under preset conditions of temperature and load. For melt mass-flow rate, timed segments of the extrudate are weighed and the extrudate rate is calculated in $\text{g}/10 \text{ min}$ and recorded. For melt volume-flow rate, the distance that the piston moves in a specified time or the time required for the piston to move a specified distance is measured to generate data in $\text{cm}^3/10 \text{ min}$. Melt volume-flow rate may be converted to melt mass-flow rate, or *vice-versa*, if the density of the material is known under the conditions of the test.

5 Apparatus**5.1 Extrusion plastometer**

The basic apparatus comprises an extrusion plastometer operating at a fixed temperature. The general design is as shown in Figure 1. The thermoplastic material, which is contained in a vertical cylinder, is extruded through a die by a piston loaded with a known weight. The apparatus consists of the following essential parts.

5.1.1 Cylinder, fixed in a vertical position (see 5.1.5). The cylinder shall be manufactured from a material resistant to wear and corrosion up to the maximum temperature of the heating system, and the finish, properties and dimensions of its surface shall not be affected by the material being tested. For particular materials, measurements may be required at temperatures up to $450 \text{ }^\circ\text{C}$. The cylinder shall have a length between 115 mm and 180 mm and an internal diameter of $9,550 \text{ mm} \pm 0,025 \text{ mm}$. The base of the cylinder shall be thermally insulated in such a way that the area of exposed metal is less than 4 cm^2 , and it is recommended that an insulating material such as Al_2O_3 , ceramic fibre or another suitable material be used in order to avoid sticking of the extrudate.

The bore shall be hardened to a Vickers hardness of no less than 500 (HV 5 to HV 100) (see ISO 6507-1) and shall be manufactured by a technique that produces a surface roughness of less than R_a (arithmetical mean deviation) = $0,25 \text{ } \mu\text{m}$ (see ISO 4287). If necessary, a piston guide shall be provided to keep friction caused by misalignment of the piston down to a minimum.

NOTE Excessive wear of the cylinder, piston head, and piston is an indication of misalignment of the piston. Regular checking for wear and change to the surface appearance of the cylinder, piston and piston head is required to ensure these items are within specification.

5.1.2 Piston, having a working length at least as long as the cylinder. The piston shall be manufactured from a material resistant to wear and corrosion up to the maximum temperature of the heating system and its properties and dimensions shall not be affected by the material being tested. The piston shall have a head $6,35 \text{ mm} \pm 0,10 \text{ mm}$ in length. The diameter of the head shall be less than the internal diameter of the cylinder by $0,075 \text{ mm} \pm 0,010 \text{ mm}$. The upper edge shall have its sharp edge removed. Above the head, the piston

shall be relieved to ≤ 9 mm diameter. A stud may be added at the top of the piston to support a removable weight, but the piston shall be thermally insulated from the weight. Along the piston stem, two thin annular reference marks shall be scribed 30 mm apart and so positioned that the upper one is aligned with the top of the cylinder when the distance between the lower edge of the piston head and the top of the die is 20 mm. These annular marks on the piston are used as reference points during the measurements (see 8.4 and 9.5).

To ensure satisfactory operation of the apparatus, the cylinder and the piston head shall be made of materials of different hardness. It is convenient for ease of maintenance and renewal to make the cylinder of the harder material.

The piston may be either hollow or solid. In tests with very low loads, the piston may need to be hollow, otherwise it may not be possible to obtain the lowest prescribed load. When the test is performed with the higher loads, a solid piston or hollow piston with guides shall be used.

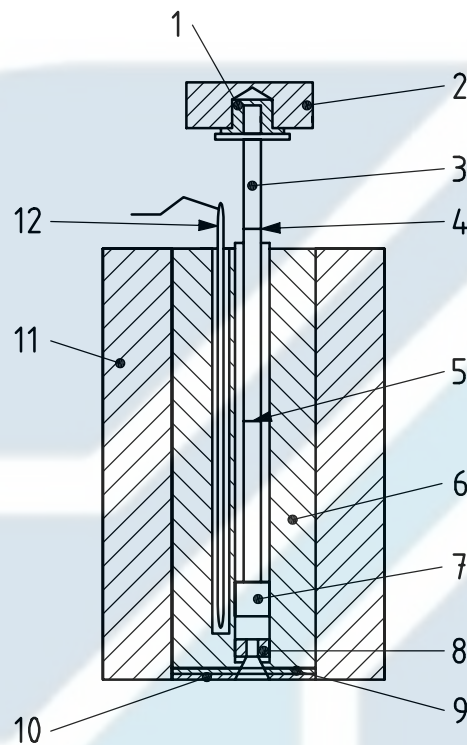

Key

- | | |
|------------------------|-----------------------|
| 1 insulation | 7 piston head |
| 2 removable weight | 8 die |
| 3 piston | 9 die retaining plate |
| 4 upper reference mark | 10 insulating plate |
| 5 lower reference mark | 11 insulation |
| 6 cylinder | 12 temperature sensor |

Figure 1 — Typical apparatus for determining melt flow rate, showing one possible configuration

5.1.3 Temperature-control system: For all cylinder temperatures that can be set, the temperature control shall be such that, between 10 mm above the top of the die and 75 mm above the top of the die, the temperature differences measured do not exceed those given in Table 1 throughout the duration of the test.

NOTE The temperature may be measured with thermocouples, platinum-resistance sensors, or mercury-in-glass thermometers embedded in the wall. If the apparatus is equipped in this way, the temperature may not be exactly the same as that in the melt, but the temperature-control system may be calibrated (see 7.1) to read in melt temperature.

The temperature-control system shall allow the test temperature to be set in steps of 0,2 °C or less.

Table 1 — Maximum allowable variation in temperature with distance and with time throughout the test

Test temperature, T °C	Maximum variation in test temperature ^a	
	with distance at between 10 mm and 75 mm above the die surface °C	with time at 10 mm above the die surface ^b °C
$125 \leq T < 250$	$\pm 2,0$	$\pm 0,5^c$
$250 \leq T < 300$	$\pm 2,5$	$\pm 0,5$
$300 \leq T$	$\pm 3,0$	$\pm 1,0$

^a Variation is over the normal time of a test, typically less than 25 min, and can be verified during calibration of the equipment.

^b When using a 4 mm length die (see 5.1.4), the readings should be made 14 mm above the die surface.

^c A value of 0,2 °C is preferred since it gives better reproducibility. It is intended that the value of 0,2 °C will become a requirement at the next revision of this International Standard.

5.1.4 Die, made of tungsten carbide or hardened steel, 8,000 mm \pm 0,025 mm in length. The interior of the bore shall be manufactured circular, straight and uniform in diameter such that in all positions it is within \pm 0,005 mm of a true cylinder of nominal diameter 2,095 mm. The bore diameter shall be checked regularly with a go/no-go gauge. If outside the tolerance limits, the die shall be discarded. The die shall have ends that are flat, perpendicular to the axis of the bore and free from visible machining marks.

If testing materials with a melt mass-flow rate $>$ 75 g/10 min or a melt volume-flow rate $>$ 75 cm³/10 min, a half-height, half-diameter die 4,000 mm \pm 0,025 mm in length and with a bore of nominal diameter 1,050 mm \pm 0,005 mm should preferably be used. No spacer shall be used with this die to increase the apparent length to 8,00 mm.

For testing potentially corrosive materials, dies made of cobalt-chromium-tungsten alloy, chromalloy, synthetic sapphire or other suitable materials may be used.

The bore shall be hardened to a Vickers hardness of no less than 500 (HV 5 to HV 100) (see ISO 6507-1) and shall be manufactured by a technique that produces a surface roughness of less than R_a (arithmetical mean deviation) = 0,25 μ m (see ISO 4287). The die shall not project beyond the base of the cylinder (see Figure 1) and shall be mounted so that its bore is co-axial with the cylinder bore.

The flat surfaces of the die shall be checked to ensure that the area around the bore is not chipped. Any chipping will cause errors and chipped dies shall be discarded.

5.1.5 Means of setting and maintaining the cylinder truly vertical: A two-directional bubble level, set normal to the cylinder axis, and adjustable supports for the apparatus are suitable for the purpose.

NOTE This is to avoid excessive friction caused by the piston leaning to one side or bending under heavy loads. A dummy piston with a spirit level on its upper end is also a suitable means of checking conformity with this requirement.

5.1.6 Load: A set of removable weights, which may be adjusted so that the combined mass of the weights and the piston gives the selected nominal load to an accuracy of \pm 0,5 %, are mounted on top of the piston.

Alternatively, a mechanical loading device combined with, for example, a load cell, providing the same level of accuracy as the removable weights, may be used.

5.2 Accessory equipment

5.2.1 General

5.2.1.1 Packing rod, made of non-abrasive material, for introducing test samples into the cylinder.

5.2.1.2 Cleaning equipment (see 7.2).

5.2.1.3 Go/no-go gauge, one end having a pin with a diameter equal to that of the die bore minus the allowed tolerance (go gauge) and the opposite end having a pin with a diameter equal to that of the die bore plus the allowed tolerance (no-go gauge). The pin gauge shall be sufficiently long to check the full length of the die using the go gauge.

5.2.1.4 Temperature-calibration device (mercury-in-glass thermometer, thermocouple, platinum-resistance sensor or other temperature-measuring device). The temperature sensor shall have a temperature readout resolution of 0,1 °C or better. Calibrate the temperature-indicating device using for example a light-gauge probe-type thermocouple or a platinum-resistance sensor having a short sensing length. The thermocouple should be encased in a metallic sheath having a diameter of approximately 1,6 mm with its hot junction grounded to the end of the sheath.

5.2.1.5 Die plug: A device shaped at one end so that it effectively blocks the die exit and prevents drool of molten material while allowing rapid removal prior to initiation of the test, e.g. a plug attached to a compressed spring.

5.2.1.6 Piston/weight support, of sufficient length to hold the piston so that the lower reference mark is 25 mm above the top of the cylinder.

5.2.2 Equipment for procedure A (see Clause 8)

5.2.2.1 Cutting tool, for cutting off extruded sample. A sharp-edged spatula has been found suitable.

5.2.2.2 Timer, accurate to ± 0,1 s for melt mass-flow rates ≤ 100 g/10 min and to ± 0,01 s for melt mass-flow rates > 100 g/10 min. Compare with a calibrated timing device over a period of 15 min to 20 min and ensure that the tolerance is within ± 0,07 % of the total time measured.

NOTE Procedure A is not recommended for measurement of melt mass-flow rates > 100 g/10 min unless using a half-height, half-diameter die.

5.2.2.3 Balance, accurate to ± 0,5 mg.

5.2.3 Equipment for procedure B (see Clause 9)

5.2.3.1 Measurement equipment, for the automatic measurement of distance and time for the piston movement, using single or multiple determinations for a single charge (see Table 2).

Table 2 — Piston distance and time measurement accuracy requirements

MFR (g/10 min) or MVR (cm ³ /10 min) ^a	Distance (mm)	Time (s)
0,1 to 1,0	± 0,02	± 0,1
> 1,0 to 100	± 0,1	± 0,1
> 100	± 0,1	± 0,01

^a For multiple measurements in a single charge regardless of the MFR or MVR of the material, the requirements are the same as for MFR or MVR > 100.

6 Test sample

6.1 Sample form

The test sample may be in any form that can be introduced into the bore of the cylinder, for example granules, strips of film, powder or sections of moulded or extruded parts. The test sample may fill the cylinder bore to a height of 75 mm prior to starting the test.

NOTE 1 In order to ensure void-free extrudates when testing powders, it may be necessary to first compress the material to a preform or pellets.

NOTE 2 The form of the test sample can be a significant factor in determining the reproducibility. The form of the test sample should therefore be controlled to improve the comparability of inter-laboratory results and to reduce the variability between runs.

6.2 Conditioning

The test sample shall be conditioned and, if considered necessary, stabilized prior to testing, in accordance with the appropriate material specification standard.

7 Temperature-calibration, cleaning and maintenance of the apparatus

7.1 Calibration of the temperature-control system

7.1.1 Calibration procedure

It is necessary to verify regularly the accuracy of the temperature-control system (5.1.3).

Set the temperature-control system to the required temperature (as indicated by the control temperature-indicating device). Charge the cylinder with a quantity of the material to be tested, or a material representative thereof (see 7.1.2), using the same technique as for a test (see 8.3). Five minutes after completing the charging of the material, introduce the calibrated temperature-indicating device (5.2.1.4) into the sample chamber and immerse it in the material therein until the sensor is 10 mm from the upper face of the die. After a further interval of not less than 4 min and not more than 10 min, correct the temperature indicated by the control temperature-indicating device by algebraic addition of the difference between the temperatures read on the two temperature sensors. It is also necessary to verify the temperature profile along the cylinder. For this, measure the temperature of the material also at 30 mm, 50 mm and 75 mm above the upper face of the die. Check the temperature over time as well as distance for conformance to Table 1. If using a calibration thermometer as the temperature-indicating device, preheat the thermometer to the same temperature as that being measured.

NOTE It is recommended that, in verifying the temperature profile along the cylinder, the measurements are started at the highest point above the die.

An alternative technique for calibration is to use a sheathed thermocouple or platinum-resistance temperature sensor with tip diameter of $9,4 \text{ mm} \pm 0,1 \text{ mm}$ for insertion in the bore without material present. Another technique is use of a piston provided with thermocouples at heights of 10 mm, 30 mm, 50 mm and 75 mm above the die, which can be inserted completely in the bore and fits the bore closely. This configuration will allow temperature calibration of the apparatus and verification of the temperature profile at the same time.

7.1.2 Calibration material

It is essential that the material used during calibration be sufficiently fluid to permit, for instance, a mercury-filled thermometer bulb to be introduced without excessive force or risk of damage. A stable material with an MFR of greater than 45 g/10 min (2,16 kg load) at the calibration temperature has been found suitable.

If such a material is used for calibration purposes in place of a more viscous material which is to be tested, the dummy material shall have a thermal diffusivity similar to that of the material to be tested, so that warm-up behaviour is similar. It is necessary that the quantity charged for calibration be such that, when the calibration temperature sensor is subsequently introduced, the appropriate length of the sensor stem is immersed for accurate temperature measurement. This can be checked by inspecting the upper edge of the material coating the end of the calibration temperature sensor, removing the sensor from the cylinder if necessary.

7.2 Cleaning the apparatus

WARNING — The operating conditions may entail partial decomposition of the material under test or any material used to clean the instrument, or cause them to release dangerous volatile substances, as well as presenting the risk of burns. The user of this International Standard is therefore responsible for keeping him- or herself informed of possible risks of accident and for providing appropriate means of protection.

The apparatus shall be cleaned thoroughly after each determination. The cylinder may be cleaned with cloth patches. The piston shall be cleaned while hot with a cotton cloth. The die may be cleaned with a closely fitting brass reamer, high-speed drill bit of 2,08 mm diameter, or wooden peg. Pyrolytic cleaning of the die in a nitrogen atmosphere at about 550 °C may also be used. Abrasives or materials likely to damage the surface of the piston, cylinder or die shall not be used. Take care that the cleaning procedure used does not affect the cylinder and die dimensions or surface finish. The die bore shall be checked with a go/no-go gauge after cleaning. When testing polyolefins, do not use copper-containing materials, e.g. brass brushes, to clean the cylinder, piston or die as this may accelerate degradation of the polymer.

If solvents are used to clean the cylinder, take care that any effect they may have on the next determination is negligible.

8 Procedure A: mass-measurement method

8.1 Selection of temperature and load

Refer to Annexes A and B. Use the conditions in Table B.1 if the material is listed there. The material standard takes precedence over this International Standard. If no material standard exists, use an appropriate set of conditions from Table A.1 based on knowledge of the melting point of the material or the processing conditions recommended by manufacturer.

8.2 Cleaning

Clean the apparatus (see 7.2). Before beginning a series of tests, ensure that the cylinder and piston have been at the selected temperature for not less than 15 min.

8.3 Selection of sample mass and charging cylinder

Charge the cylinder with 3 g to 8 g of the sample according to the anticipated MFR or MVR (see Table 3). During the charging, compress the material with the packing rod (5.2.1.1), using hand pressure. For materials susceptible to oxidative degradation, ensure the charge is as free from air as possible. Complete the charging process in < 1 min. The preheat time of 5 min begins after charging of the cylinder has been completed.

NOTE Variations in the packing pressure used to compress the material in the cylinder can cause poor repeatability of results. Use of the same mass of sample for the analysis of materials of similar MFR or MVR will reduce variability in the data.

Immediately put the piston in the cylinder. The piston may be either unloaded or preloaded with the test weight or, for materials with high flow rates, a smaller weight. If the melt mass-flow rate or melt-volume flow rate of the material is high, that is, more than 10 g/10 min or 10 cm³/10 min, the loss of sample during preheating will be appreciable. In this case, use an unloaded piston or one carrying a smaller load during the preheating period, and then change to the desired load at the end of the 5 min preheating time. In the case of very high

melt flow rates, a weight support should preferably be used and a die plug may be necessary. If the die plug is used and less than the desired load is on the piston, add the desired load and allow the material to stabilize for a few seconds before removing the die plug. If a weight support and die plug are both used, remove the weight support first.

NOTE To minimize the risk of burns from hot material coming out of the die rapidly, it is recommended that heat-resistant gloves be worn during the removal of the die plug.

Table 3 — Guidelines for experimental parameters

MFR (g/10min) or MVR (cm ³ /10min) ^a	Mass of test sample in cylinder ^{b, c} g	Extrudate cut-off time-interval s
≥ 0,1 but ≤ 0,5	3 to 5	240
> 0,5 but ≤ 1	4 to 6	120
> 1 but ≤ 3,5	4 to 6	60
> 3,5 but ≤ 10	4 to 8	30
> 10	4 to 8	5 to 15 ^d

^a It is recommended that a melt flow rate should not be measured if the value obtained in this test is less than 0,1 g/10 min (MFR) or 0,1 cm³/10 min (MVR). Melt mass-flow rates greater than 100 g/10 min should only be measured if the timer resolution is 0,01 s and procedure B is used when a standard 8,00 mm die is used. Alternatively, the half-height, half-diameter die may be used with procedure A (see 5.1.4).

^b When the density of the material is greater than 1,0 g/cm³, it may be necessary to increase the mass of the test sample. Use the low mass values for low-density materials.

^c Sample mass is a significant factor in determining the repeatability of this test and may need to be controlled to 0,1 g to reduce variability between runs.

^d To achieve adequate repeatability when testing materials having an MFR greater than 25 g/10 min (or MVR greater than 25 cm³/10 min), it may be necessary either to control and measure cut-off intervals to an accuracy of less than 0,1 s or to use procedure B.

8.4 Measurements

8.4.1 Five minutes after completing the introduction of the test sample, place the selected weight on the piston, if it was unloaded or under-loaded. During this time, check that the temperature has returned to that selected. Allow the piston to descend under gravity until a bubble-free filament is extruded; this may be done before or after loading, depending on the actual viscosity of the material. It is strongly recommended that forced purging of the sample, done either manually or by using extra weights, before commencement of the test be avoided. If any forced purging is required (i.e. to complete the procedure within the specified time limit), it shall be finished at least 2 min before the start of the test. Any purging shall be carried out within a period of 1 min. Cut off the extrudate with the cutting tool (5.2.2.1), and discard. Continue to allow the loaded piston to descend under gravity. When the lower reference mark has reached the top edge of the cylinder, start the timer (5.2.2.2), and simultaneously cut off the extrudate with the cutting tool and again discard.

NOTE For some materials, shorter times may be required to prevent degradation and for high melting point, high T_g , low thermal conductivity and similar materials, e.g. PMMA, longer times may be needed to obtain repeatable results.

8.4.2 Collect successive cut-offs in order to measure the extrusion rate at a given time-interval. Depending on the melt mass-flow rate, choose a time-interval so that the length of a single cut-off is not less than 10 mm and preferably between 10 mm and 20 mm (see cut-off time-intervals in Table 3 as a guide).

For low values of MFR (and MVR) and/or materials which exhibit a relatively high degree of die swell, it may not be possible to take a cut-off with a length of 10 mm or more within the maximum time-interval of 240 s. In such cases, procedure A may be used, but only if the mass of each cut-off obtained in 240 s is greater than 0,04 g. If not, procedure B shall be used.

8.4.3 Stop cutting when the upper mark on the piston stem reaches the top edge of the cylinder. Discard any cut-off containing visible air bubbles. After cooling, weigh individually, to the nearest 1 mg, the remaining cut-offs, preferably three or more, and calculate their average mass. If the difference between the maximum and the minimum values of the individual weighings exceeds 15 % of the average, discard the results and repeat the test on a fresh portion of the sample. For materials suspected to be non-homogeneous, such as recycled material, it is recommended that the cut-offs be weighed in order of extrusion. If a continuous change in mass is observed, this shall be reported as unusual behaviour (see Clause 12).

8.4.4 The time between the end of charging the cylinder and the last measurement shall not exceed 25 min for any material. For some materials, this time may need to be reduced to prevent degradation or crosslinking of the material during the test.

8.5 Expression of results

8.5.1 The melt mass-flow rate (MFR), expressed in grams per 10 min, is given by the equation

$$MFR(T, m_{nom}) = \frac{600m}{t}$$

where

- T* is the test temperature, in degrees Celsius;
- m_{nom}* is the nominal load, in kilograms;
- m* is the average mass, in grams, of the cut-offs;
- t* is the cut-off time-interval, in seconds;
- 600 is the factor used to convert grams per second into grams per 10 min (600 s).

8.5.2 The melt volume-flow rate may also be calculated from the melt mass-flow rate using the following equation:

$$MVR = MFR / \text{Melt density of material}$$

8.5.3 Express the result to two significant figures (three significant figures for results < 10,0) and record the test temperature and load used (e.g. 190/2,16).

9 Procedure B: displacement-measurement method

9.1 Selection of temperature and load

See 8.1.

9.2 Minimum piston displacement distance

For improved accuracy and repeatability of measurements of low melt flow rate materials, e.g. MFR < 1,0 g/10 min or MVR < 1,0 cm³/10 min, the following minimum piston displacement distances are suggested:

MFR or MVR range	Distance (minimum)
> 0,10 but ≤ 0,15	3 mm
> 0,15 but ≤ 0,40	4 mm
> 0,40 but ≤ 1,0	10 mm
> 1,0	20 mm

9.3 Timer

Where the displacement measurement and/or timing device used for piston displacement measurement makes physical contact with the piston or weight, the load shall not be altered by more than 0,5 % of the total load.

9.4 Preparation for the test

As in procedure A (follow 8.2 to 8.4.1).

9.5 Measurements

9.5.1 Do not start taking measurements before the lower reference mark has reached the top edge of the cylinder.

9.5.2 Take measurements as follows:

a) Either measure the distance moved by the piston at predetermined times.

NOTE For some materials, results can vary depending on the distance moved by the piston. For improved repeatability, it is critical to maintain the same distance moved between individual runs.

b) Or measure the times taken by the reference mark to cover a specified distance.

Stop the measurements when the upper mark on the piston stem reaches the edge of the cylinder.

9.5.3 The time between the end of charging the cylinder and the last measurement shall not exceed 25 min for any material. For some materials, this time may need to be reduced to prevent degradation or crosslinking of the material during the test.

9.6 Expression of results

9.6.1 The melt volume-flow rate (MVR), expressed in cubic centimetres per 10 min, is given by the equation

$$\text{MVR}(T, m_{\text{nom}}) = \frac{A \ 600 \ l}{t}$$

where

T is the test temperature, in degrees Celsius;

m_{nom} is the nominal load, in kilograms;

A is the mean of the cross-sectional areas of the cylinder and the piston head, in square centimetres (nominally 0,711 cm² but, based on the tolerances allowed on the cylinder diameter, the product $A \times 600$ can vary from 424 to 428 and shall be calculated for the geometry of the cylinder actually used for the test);

t is the predetermined time of measurement or the mean value of the individual time measurements, in seconds (see 9.5.2);

l is the predetermined distance moved by the piston or the mean value of the individual distance measurements, in centimetres (see 9.5.2).

9.6.2 The melt mass-flow rate (MFR), expressed in grams per 10 min, is given by the equation

$$\text{MFR}(T, m_{\text{nom}}) = \frac{A \ 600 \ l \ \rho}{t}$$

where

T , m_{nom} , A , t and l are as defined in 9.6.1;

ρ is the density, in grams per cubic centimetre, of the melt at the test temperature and is given by the equation

$$\rho = \frac{m}{Al}$$

m being the mass, in grams, determined by weighing, of extrudate expelled by a piston movement of l cm.

9.6.3 Express the result to two significant figures (three significant figures for results $< 10,0$) and record the test temperature and load used (e.g. 190/2,16).

10 Flow rate ratio (FRR)

The ratio of two values of MFR (or MVR) obtained for a material tested at the same temperature but with different loads is called the flow rate ratio, e.g.

$$\text{FRR} = \frac{\text{MFR}(190/10,0)}{\text{MFR}(190/2,16)}$$

It is commonly used as an indication of the way in which the rheological behaviour of a thermoplastic is influenced by the molecular mass distribution of the material.

NOTE The conditions to be used for the determination of the flow rate ratio are given in the appropriate material standards.

Express results to two significant figures (or three if both the MFR and MVR are expressed to three).

11 Precision

When the method is used with certain materials, consideration shall be given to the factors which may influence the magnitude of the measured values and may lead to a decrease in repeatability. Such factors include the following:

- a) thermal degradation or crosslinking of the material, causing the melt flow rate to change during the preheating or test period (powdered materials requiring long preheating times are sensitive to this effect and, in certain cases, the inclusion of stabilizers is necessary to reduce the variability);
- b) with filled or reinforced materials, the distribution or orientation of the filler may affect the melt flow rate.

The precision of the method is not known because interlaboratory data are not available. A single precision statement would not be suitable because of the number of materials covered. However, a coefficient of variation of about $\pm 10\%$ could be expected between laboratories and $\pm 5\%$ within a laboratory.

12 Test report

The test report shall include the following particulars:

- a) a reference to this International Standard;
- b) all details necessary for the complete identification of the test sample, including the physical form of the material with which the cylinder was charged;
- c) the details of conditioning;
- d) the details of any stabilization (see 6.2);
- e) the die dimensions;
- f) the temperature and load used in the test;
- g) the pre-heat time used;
- h) for procedure A, the masses of the cut-offs and the cut-off time-intervals or, for procedure B, the predetermined time of measurement or distance moved by the piston and the corresponding measured values of the distance moved by the piston or the time of measurement;
- i) the melt mass-flow rate, in grams per 10 min, or the melt volume-flow rate, in cubic centimetres per 10 min, expressed to two significant figures (three significant figures for results < 10,0) (when more than one value has been obtained, all the individual values shall be reported, as well as the mean value);
- j) if appropriate, the flow rate ratio (FRR);
- k) a report of any unusual behaviour of the test sample, such as discoloration, sticking, extrudate distortion or unexpected variation in melt flow rate;
- l) the date of the test.

MAHCO

Annex A (normative)

Test conditions for MFR and MVR determinations

The conditions used shall be as indicated in the appropriate material specification standard. Table A.1 indicates test temperatures and loads that have been found useful.

Table A.1

Test temperature, T , °C

100
125
150
190
200
220
230
235
240
250
260
265
275
280
300

Nominal load (combined), m_{nom} , kg

0,325
1,20
2,16
3,80
5,00
10,00
21,60

NOTE 1 It is recommended that temperatures and loads from this table be used for new thermoplastic materials. Any combination of temperature and load may be used. However, the choice of temperature and load combination(s) should be based on the rheological properties of the material and be defined in the material specification standard.

NOTE 2 The code-letters that were used in the past to describe combinations of temperature and load have been eliminated from this table and will be phased out of Table B.1.

Annex B (informative)

Conditions specified in International Standards for the determination of the melt flow rate of thermoplastic materials

Table B.1 indicates test conditions that are currently specified in relevant International Standards or by agreement with the relevant ISO committee. All standards are subject to revision, and the test conditions should be verified with the current material standard prior to testing. Other test conditions not listed here may be used, if necessary, for a particular material (see Annex A).

Table B.1

International Standard (see Clause 2)	Materials	Conditions (code-letter)	Test temperature, T °C	Nominal load (combined), m_{nom} kg
ISO 1622-2	PS	H	200	5,00
ISO 1872-2	PE ^a	D	190	2,16
ISO 1872-2	PE ^a	E	190	0,325
ISO 1872-2	PE ^a	G	190	21,60
ISO 1872-2	PE ^a	T	190	5,00
ISO 1873-2	PP ^a	M	230	2,16
ISO 1873-2	PP ^a		230	5,00
ISO 2580-2	ABS	U	220	10,00
ISO 2580-2	ABS		240	10,00
ISO 2580-2	ABS		265	10,00
ISO 2897-2	PS-I	H	200	5,00
ISO 4613-2	EVAC ^b	B	150	2,16
ISO 4613-2	EVAC ^b	D	190	2,16
ISO 4613-2	EVAC ^b	Z	125	0,325
ISO 4894-2	SAN	U	220	10,00
ISO 6402-2	ASA, ACS, AEDPS	U	220	10,00

Table B.1 (continued)

International Standard (see clause 2)	Materials	Conditions (code letter)	Test temperature, T °C	Nominal load (combined), m_{nom} kg
ISO 6402-2	ASA, AEDPS		240	10,00
ISO 6402-2	ASA, AEDPS		265	10,00
ISO 7391-2	PC ^c	W	300	1,20
ISO 8257-2	PMMA	N	230	3,80
ISO 8986-2	PB	D	190	2,16
ISO 8986-2	PB	F	190	10,00
ISO 15876-3	PB	T	190	5,00
ISO 9988-2	POM	D	190	2,16
ISO 15494	PP	T	190	5,00
ISO 10366-2	MABS	U	220	10,00

^a Melt density values for this material are included in the material standard.

^b For EVAC, set of conditions B or D is used for MFRs up to 100 g/10 min; set of conditions Z is used for MFRs > 100 g/10 min under set of conditions B.

^c Sample must be dried to $\leq 0,02$ % moisture level prior to testing.





MAHCO

MEHR AB HAYAT SANAAT KERMAN
www.MAHCOpipe.com



ICS 83.080.20

Price based on 16 pages

MEHR AB HAYAT SANAAT KERMAN
www.MAHCOpipes.com