**Thermoplastics pipes — Determination
of tensile properties —**

Part 2:

Pipes made of unplasticized poly(vinyl chloride) (PVC-U), chlorinated poly(vinyl chloride) (PVC-C) and high-impact poly(vinyl chloride) (PVC-HI)

Tubes en matières thermoplastiques — Détermination des caractéristiques en traction —

Partie 2: Tubes en poly(chlorure de vinyle) non plastifié (PVC-U), poly(chlorure de vinyle) chloré (PVC-C) et poly(chlorure de vinyle) à résistance au choc améliorée (PVC-choc)

This material is reproduced from ISO documents under International Organization for Standardization (ISO) Copyright License number IHS/ICC/1996. Not for resale. No part of these ISO documents may be reproduced in any form, electronic retrieval system or otherwise, except as allowed in the copyright law of the country of use, or with the prior written consent of ISO (Case postale 56, 1211 Geneva 20, Switzerland, Fax +41 22 734 10 79), IHS or the ISO Licensor's members.



Foreword

ISO (the International Organization for Standardization) is a worldwide federation of national standards bodies (ISO member bodies). The work of preparing International Standards is normally carried out through ISO technical committees. Each member body interested in a subject for which a technical committee has been established has the right to be represented on that committee. International organizations, governmental and non-governmental, in liaison with ISO, also take part in the work. ISO collaborates closely with the International Electrotechnical Commission (IEC) on all matters of electrotechnical standardization.

Draft International Standards adopted by the technical committees are circulated to the member bodies for voting. Publication as an International Standard requires approval by at least 75 % of the member bodies casting a vote.

International Standard ISO 6259-2 was prepared by Technical Committee ISO/TC 138, *Plastics pipes, fittings and valves for the transport of fluids*, Subcommittee SC 5, *General properties of pipes, fittings and valves of plastic materials and their accessories — Test methods and basic specifications*.

ISO 6259 consists of the following parts, under the general title *Thermoplastics pipes — Determination of tensile properties*:

- *Part 1: General test method*
- *Part 2: Pipes made of unplasticized poly(vinyl chloride) (PVC-U), chlorinated poly(vinyl chloride) (PVC-C) and high-impact poly(vinyl chloride) (PVC-HI)*
- *Part 3: Polyolefin pipes*

Annexes A to D of this part of ISO 6259 are for information only.

© ISO 1997

All rights reserved. Unless otherwise specified, no part of this publication may be reproduced or utilized in any form or by any means, electronic or mechanical, including photocopying and microfilm, without permission in writing from the publisher.

International Organization for Standardization
Case postale 56 • CH-1211 Genève 20 • Switzerland
Internet central@iso.ch
X.400 c=ch; a=400net; p=iso; o=isocs; s=central

Printed in Switzerland

Thermoplastics pipes — Determination of tensile properties —

Part 2:

Pipes made of unplasticized poly(vinyl chloride) (PVC-U), chlorinated poly(vinyl chloride) (PVC-C) and high-impact poly(vinyl chloride) (PVC-HI)

1 Scope

This part of ISO 6259 specifies a method of determining the tensile properties of pipes made of poly(vinyl chloride) (PVC-U), chlorinated poly(vinyl chloride) (PVC-C) and high-impact poly(vinyl chloride) (PVC-HI), and in particular the following properties:

- the stress at yield;
- the elongation at break.

NOTE — The general method of test for the determination of the tensile properties of thermoplastics pipes is given in ISO 6259-1.

This part of ISO 6259 also gives, for information purposes only, the corresponding basic specifications in annexes A, B and C.

2 Normative reference

The following standard contains provisions which, through reference in this text, constitute provisions of this part of ISO 6259. At the time of publication, the edition indicated was valid. All standards are subject to revision, and parties to agreements based on this part of ISO 6259 are encouraged to investigate the possibility of applying the most recent edition of the standard listed below. Members of IEC and ISO maintain registers of currently valid International Standards.

ISO 6259-1:1997, *Thermoplastics pipes — Determination of tensile properties — Part 1: General test method.*

3 Principle

See clause 3 of ISO 6259-1:1997, as applicable to thermoplastics covered by this part of ISO 6259.

4 Apparatus

See clause 4 of ISO 6259-1:1997.

5 Test pieces

See clause 5 of ISO 6259-1:1997.

5.1 Nature of the test pieces

5.1.1 General

See clause 5 of ISO 6259-1:1997.

5.1.2 Dimensions of test pieces

Depending on the method by which they are prepared (see 5.2), the shape and dimensions of the test pieces shall conform to table 1 and figure 1 or table 2 and figure 2, as applicable.

5.2 Preparation of test pieces

5.2.1 The test pieces shall be taken from the centre of strips cut from the length of pipe in accordance with 5.2.1 of ISO 6259-1:1997 and with 5.2.2 or 5.2.3 of this part of ISO 6259, as applicable.

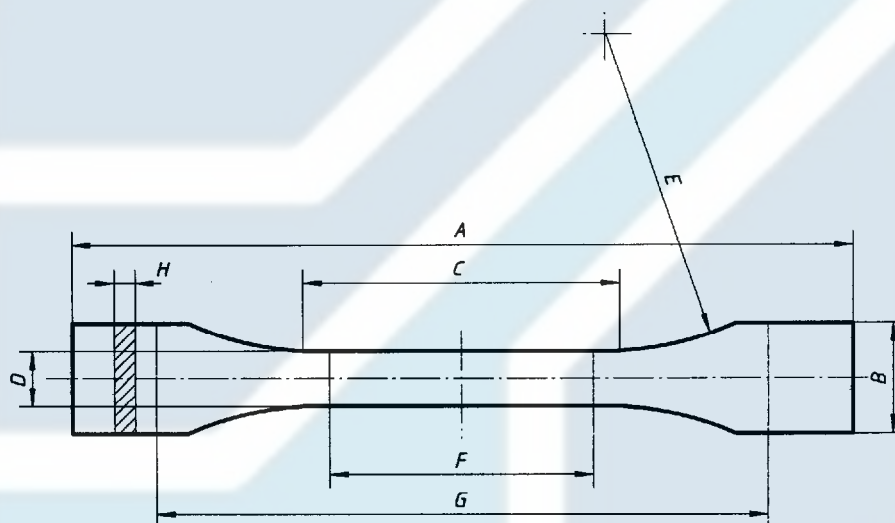

Figure 1 — Test piece obtained by machining (type 1)

Table 1 — Dimensions of test pieces prepared by machining

Symbol	Description	Dimensions mm
A	Minimum total length	115
B	Width of ends	≥ 15
C	Length of narrow, parallel-sided portion	33 ± 2
D	Width of narrow, parallel-sided portion	$6^{+0,4}_0$
E	Radius	14 ± 1
F	Gauge length	25 ± 1
G	Initial distance between grips	80 ± 5
H	Thickness	That of the pipe

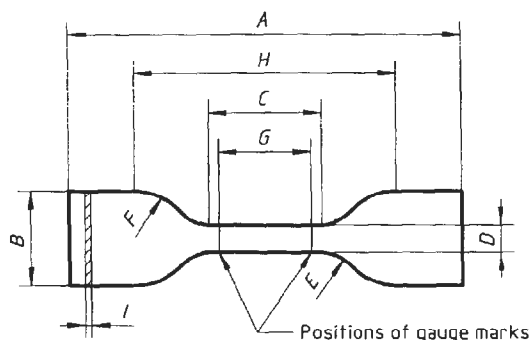

Figure 2 — Test piece obtained by die cutting (type 2)

Table 2 — Dimensions of test pieces obtained by die cutting

Symbol	Description	Dimensions mm
A	Minimum total length	115
B	Width of ends	25 ± 1
C	Length of narrow, parallel-sided portion	33 ± 2
D	Width of narrow, parallel-sided portion	6 ^{+0,4} / ₀
E	Small radius of curvature	14 ± 1
F	Large radius of curvature	25 ± 2
G	Gauge length	25 ± 1
H	Initial distance between grips	80 ± 5
I	Thickness	That of the pipe

5.2.2 For unplasticized poly(vinyl chloride) (PVC-U) pipes and pipes made of high-impact poly(vinyl chloride) (PVC-HI), test pieces shall be prepared in accordance with item a) or item b) as applicable:

- a) Pipes of wall thickness less than or equal to 12 mm

The test pieces may be prepared either by die cutting (see figure 2), or by machining (see figure 1), except that, for interlaboratory comparison and reference tests, the test pieces shall be machined.

- b) Pipes of wall thickness greater than 12 mm

The test pieces may be prepared only by machining (see figure 1).

5.2.3 For chlorinated poly(vinyl chloride) (PVC-C) pipes and pipes made from a mixture of poly(vinyl chloride) and chlorinated poly(vinyl chloride) (PVC-U/PVC-C), the test pieces shall only be prepared by machining, whatever the thickness.

5.3 Cutting method (see 5.2.2.2 in ISO 6259-1:1997)

Use a cutting die (4.6 in ISO 6259-1:1997) with a profile as shown in figure 2.

Heat the strip in an oven maintained at a temperature between 125 °C and 130 °C, for 1 min per millimetre of thickness.

Cut out the test piece as soon as the strip is taken out of the oven, applying the die cutter to the inner surface of the strip and exerting a continuous uniform pressure. Then leave it to cool at ambient temperature in still air.

NOTE — It may be necessary to heat the die.

5.4 Machining method (see 5.2.2.3 in ISO 6259-1:1997)

For pipes of nominal outside diameter greater than 110 mm, machine the strip as cut.

For pipes of nominal outside diameter less than or equal to 110 mm, machine the strip after it has been flattened under the following conditions:

- a) temperature:
 - 125 °C to 130 °C for PVC-U or PVC-HI pipes,
 - 135 °C to 140 °C for PVC-C pipes or pipes made from PVC-U/PVC-C mixtures;
- b) duration of heating: 1 min per millimetre of thickness;
- c) flattening pressure: a value such that it does not cause any reduction in the thickness of the plate.

Cool in air to ambient temperature.

6 Conditioning

See clause 6 of ISO 6259-1:1997.

7 Test speed

The test speed, i.e. the speed of separation of the grips, shall be $(5 \pm 0,5)$ mm/min for all test pieces, regardless of thickness.

8 Procedure

See clause 8 of ISO 6259-1:1997.

9 Expression of results

See clause 9 of ISO 6259-1:1997.

10 Test report

See clause 10 of ISO 6259-1:1997.

MAHCO

Annex A (informative)

Unplasticized poly(vinyl chloride) (PVC-U) pipe — Basic specification

It is recommended that the minimum tensile properties of unplasticized poly(vinyl chloride) (PVC-U) pipes, measured under the test conditions given in ISO 6259-1, are as follows:

- a) stress at yield: $\sigma \geq 45$ MPa;
- b) elongation at break: $\varepsilon \geq 80$ %.



Annex B (informative)

Chlorinated poly(vinyl chloride) (PVC-C) pipes and pipes made from mixtures of poly(vinyl chloride) and chlorinated poly(vinyl chloride) (PVC-U/PVC-C) — Basic specification

It is recommended that the minimum tensile properties of PVC-C pipes and pipes made from a PVC-U/PVC-C mixture, measured under the test conditions given in ISO 6259-1, are as follows:

- a) Pipes for pressure applications:
 - stress at yield: $\sigma \geq 50$ MPa;
 - elongation at break: $\varepsilon \geq 40$ %.
- b) Pipes for non-pressure applications:
 - stress at yield: $\sigma \geq 45$ MPa;
 - elongation at break: $\varepsilon \geq 70$ %.

The logo for MAHCO is a large, light blue graphic consisting of several overlapping, curved shapes that form a stylized, abstract representation of a pipe or a structural element. Below this graphic, the word "MAHCO" is written in a large, bold, light blue serif font.

MAHCO

Annex C (informative)

High-impact poly(vinyl chloride) (PVC-HI) pipes — Basic specification

It is recommended that the minimum tensile properties of PVC-HI pipes, measured under the test conditions given in ISO 6259-1, are as follows:

- a) stress at yield: $\sigma \geq 40$ MPa;
- b) elongation at break: $\varepsilon \geq 80$ %.



Annex D
(informative)

Bibliography

- [1] ISO 527-2:1993, *Plastics — Determination of tensile properties — Part 2: Test conditions for moulding and extrusion plastics.*





ICS 23.040.20

Descriptors: pipes (tubes), polyvinyl chloride, chlorinated polyvinyl chloride, plastic tubes, tests, tension tests, determination, tensile properties.

Price based on 8 pages

MEHR AB HAYAT SANAAT KERMAN

www.MAHCOpipe.com