

IGS-M-PL-014-3(2)

Jan.2018

Approved

مصوب



شرکت ملی گاز ایران

مدیریت پژوهش و فناوری

امورتدوین استانداردها

IGS

مشخصات فنی خرید

گازرسانی پلی اتیلن : اتصالات فولاد به پلی اتیلن

P.E. Gas Piping : Transition Fittings (T.F.)



تاریخ: ۱۳۹۶/۱۲/۲۷

شماره: ک.ا.ب. ۰۱۹/۰-۱۸۲۵۹



شرکت ملی گاز ایران



دفتر مدیر عامل

ابلاغ مصوبه هیأت مدیره

مدیر محترم پژوهش و فناوری

باسلام،

به استحضار می‌رساند در جلسه ۱۷۷۲ مورخ ۱۳۹۶/۱۲/۱۹ هیأت مدیره، نامه شماره گ.ا.ب. ۱۶۶۷۰۱/۰۰۰/۹ مورخ ۹۶/۱۲/۱۴ مدیر پژوهش و فناوری در مورد تصویب نهایی استاندارد به شرح زیر مطرح و مورد تصویب قرار گرفت:

۱. مشخصات فنی تجهیزات گرم کننده گاز (غیر مستقیم - آبی) نوع مشعل دمنده دار

IGS-M-PM-106(1)

۲. مشخصات فنی خرید اتصالات فولاد به پلی اتیلن

IGS-M-PL-014-3(2)

۳. دستورالعمل بازرسی ساید بوم

IGS-I-GN-007(0)

۴. مشخصات فنی گوگرد دانه بندی

IGS-M-CH-060(0)

۵. مشخصات فنی کود گوگرد بنتونیتی

IGS-M-CH-061(0)

این مصوبه در حکم مصوبه مجمع عمومی شرکت‌های تابعه محسوب و برای کلیه شرکت‌های تابعه لازم الاجرا می‌باشد.

الهام ملکی

مدیر هیأت مدیره

MAHCO

رونوشت: مدیر عامل محترم شرکت ملی گاز ایران و رئیس هیأت مدیره

اعضای محترم هیأت مدیره

مشاور و رئیس دفتر محترم مدیر عامل

رئیس کل محترم امور حسابرسی داخلی

رئیس محترم امور حقوقی

رئیس محترم امور منابع

FOREWORD

This standard is intended to be mainly used by NIGC and contractors, and has been prepared based on interpretation of recognized standards, technical documents, knowledge, backgrounds and experiences in natural gas industry at national and international levels. Iranian Gas Standards (IGS) are prepared, reviewed and amended by technical standard committees within NIGC Standardization division and submitted to the NIGC's "STANDARDS COUNCIL" for approval. IGS Standards are subject to revision, amendment or withdrawal, if required. Thus the latest edition of IGS shall be checked/inquired by NIGC employees and contractors. This standard must not be modified or altered by NIGC employees or its contractors. Any deviation from normative references and / or well-known manufacturer's specifications must be reported to Standardization division. The technical standard committee welcomes comments and feedbacks about this standard, and may revise this document accordingly based on the received feedbacks.

GENERAL DEFINITIONS:

Throughout this standard the following definitions, where applicable, should be followed:

- 1- "STANDARDIZATION DIV." is organized to deal with all aspects of industry standards in NIGC. Therefore, all enquiries for clarification or amendments are requested to be directed to mentioned division.
- 2- "COMPANY": refers to National Iranian Gas Company (NIGC).
- 3- "SUPPLIER": refers to a firm who will supply the service, equipment or material to NIGC whether as the prime producer or manufacturer or a trading firm.
- 4- "SHALL ": is used where a provision is mandatory.
- 5- "SHOULD": is used where a provision is advised only.
- 6- "MAY": is used where a provision is completely discretionary.

Website: <http://igs.nigc.ir>
E-mail: igs@nigc.ir

Content

<u>Title</u>	<u>Page</u>
1. Scope.....	2
2. References.....	2
2.1. Normative reference.....	2
2.2. Informative reference.....	2
3. Definition.....	2
4. General description.....	3
5. Material.....	3
5.1. Steel part.....	3
5.2. PE part.....	3
6. Required characteristics (table 1).....	4
7. Minimum length of PE & steel part & steel part wall thickness.....	6
7.1. Spigot Type Transition Fitting (T.F.).....	6
7.2. Injection Type Transition Fitting (T.F.).....	6
8. Inspection & testing.....	7
9. Marking.....	7
10. Documentation	7
11. Packaging.....	7
12. Informative Annex1, 2 (Typical transition fitting).....	8
13. Informative Annex3 (Typical transition fitting).....	10
14. Informative Annex4 (Typical transition fitting).....	11

1.0. Scope

This standard specification covers N.I.G.C requirement for material testing, inspection, dimension , tolerance , marking , packing . handling, storage , and transportation for transition fitting in accordance with CEN specification EN 1555,2013edition .

The applicability of this specification shall be mutually agreed upon by the purchaser and manufacturer.

Annexes 1 & 2 & 3 &4 of this standard are for information only

2.0. References

2.1. Normative reference

EN 1555-3, 2013 edition plastic system for supply of gaseous fuels –polyethylene (PE)- part 3 Fitting

ISO 10838-1 (2000 edition)

BS ISO 10838 -1&2 (2000 edition) mechanical fitting for polyethylene piping system for supply of gaseous fuels PE pipe

2.2. Informative reference

IGS –M-PL-014-1(3)(2015 edition) PE pipe part 1

3.0. Definition

3.1. Minimum Bore

Smallest internal diameter, measured at any cross –section of fitting assembly.

3.2. Lot or Production Batch

Clearly identifiable collection of units , manufactured consecutively or continuously under the same conditions , using material or compound conforming to the same specification .

3.3. Routine Test

Refer to non –destructive or short duration test

3.4. Type Test

Testing performed to prove that the material, component, assembly is capable of conforming to the requirements given in the relevant standard. In addition, relevant type tests shall be carried out and relevant certificate shall be submitted whenever there is a change in design, and /or in the production method other than routine in – process adjustment and any change in raw material such as brand, production designation , production location . In case of no changes in mentioned above items every five years the type tests certificate shall be renewed.

4.0. General Description

Transition fitting comprises carbon steel and PE parts.

The carbon steel part of the TF shall be connected to carbon steel pipe by electric welding,

TF shall be such designed that PE part and carbon steel part joined together Permanently and when it is subjected to tensile strength test, the PE part yield zone shall be away from PE - carbon steel joint.

The minimum internal bore diameter shall be stated by manufacturer in his technical data sheet.

It shall not be restricted by liners or other components by more than 15% of the bore diameter of the corresponding PE pipe.

The internal and external surface of TF shall be smooth and free from scoring, cavities and other surface defects likely to impair their performance. All mechanical characteristic test requirements and dimensions of final fabrication of TF shall be according to table 1.

5.0. Material

5.1. Steel Part

5.1.1. Steel part shall be black, beveled end, ERW or seamless, electric furnace, open hearth of basic oxygen steel for spigot type TF and seamless for injection type TF according to API 5L grade B or ASTM A 53 grade B.

5.1.2. For spigot type TF, the spigot shall be seamless made of mild carbon steel weld able to API 5L grade B or ASTM A 53 grade B.

5.1.3. For injection type TF, steel part shall be seamless weld able to API 5L grade B or ASTM A 53 grade B

5.1.4. Carbon steel part of TF shall be zinc electroplated according to B.S 1706 ZN3

5.1.5. A length equal to 40 ± 5 mm of steel part end shall not be coated.

5.2. PE Part

PE part shall be PE 100,SDR 11 for sizes 25mm up to 90mm and PE 100, SDR 13.6for sizes 110mm up to 225mm , black , according to IGS-M-PL-014(۲) ,20۱۰,part 1.

MAHCO

6.0. REQUIRED CHARACTERISTICS

TABLE 1

ELEMENT	REQUIRMENT	TESTPARAMETERS		TESTMETHOD	TYPE OF TEST	NO.Of SAMPL
		PARAMETER	VALUE			
LEAKTIGHTNESS TEST WITH AIR	NO LEAKAGE ⁽¹⁾	TEST TEMP PRESSURE Time	Room temperature 6bar 1min.	ISO 10838-1,2 2000 EDITION	ROUTINE TEST	ALL PRODUCTS
HYDROSTATIC STRENGTH (80°C, 1000 hr.)	NO FAILURE DURING TEST PERIOD	CIRCUMFERENTIAL (HOOP STRESS) PE100	5,0Mpa	ISO 10838-1,2 2000 EDITION	TYPE TEST ⁽²⁾	ONE / SIZE
HYDROSTATIC STRENGTH (DELAYBURSTTEST)	WITHSTAND ONE HOUR PERIOD	END CAPS ORIENTATION TEST PRESSURE INTERNAL PRESSURE	TYPE (A) FREE 24bar 24bar	ISO10838-1 (1996 EDITION)	ROUTIN TEST	FOR GROUP ONE ⁽³⁾ 3 SAMLES/LOT FOR GROUP TWO ⁽⁴⁾ 1 SAMPLE /LOT
LEAKTIGHTNESS WITH BENDING & TEMP CYCLING FOR dn≤63mm	NO LEAKAGE	TEST PERESSURE CYCLE TEST: NUMBER OF CYCLES Tmin Tmax	6bar 10 -20°C +40°C	ISO 10838-1 2000 EDITION & ISO3503	TYPE TEST	ONE / SIZE
LEAKTIGHTNESS WITH TEMP CYCLING FOR dn>63mm	NO LEAKAGE	TEST PERESSURE CYCLE TEST: NUMBER OF CYCLES Tmin Tmax	6bar 10 -20°C +40°C	ISO10838-2 2000 EDITION	TYPE TEST	ONE / SIZE
LEAKTIGHTNESS AFTER TENSILE TEST UNDER CONSTANTLOAD 12 Mpa , 1 hr ⁽⁶⁾	NO FAILUER NO LEAKAGE	CONSTANT TENSILE LOAD PERIOD OF TENSILE TEST LEAKTIGHTNESS	12Mpa 1hr	ISO 108381&2 2000 EDITION	ROUTINE TEST	ONE / LOT/ SIZE ⁽⁶⁾
LEAKTIGHTNESS AFTER TENSILE TEST UNDER CONSTANT LOAD (80°C, 500hr.)	NO LEAKAGE	PRESSURE DURATION TEMPRATURE CONSTANTLOAD	25 mbar 24 hr 80 °C Acc.TO ISO 10838 1&2	ISO 108381&2 2000 EDITION	TYPE TEST	ONE / SIZE
Conventional * density conforming to EN ISO 1872 -1 (type test)	945 kg /m3 (base polymer)	Test temperature Number of test pieces a	23°C Shall conform to ISO 1183	EN 1183-1/2	TYPE TEST	ONE / LOT/SIZE

* Melt mass flow rate (MFR) (type test)	0.2 _ MFR_ 0.7 g/10min After processing Maximum deviation of $\pm 10\%$ of the value measured on the batch used to manufacture the fitting	Loading mass Test temperature Time Number of test Piece ^a	5kg 190°C 10 min Shall conform to EN ISO1133:2011	EN ISO 133:2011	TYPE TEST	ONE / LOT/SIZE
* Oxidation induction time (thermal stability) (type test)	> 20 min	Test temperature Number of test Piece ^a	200°C 3	ISO/FDIS 11357-6	TYPE TEST	ONE / LOT/SIZE
* Carbon black content	(2to 2.5)% (by mass)	Shall conform to ISO 6964		ISO 6964	TYPE TEST	ONE / LOT/SIZE
* Carbon black dispersion	Grade 3	Preparation of test pieces Number of test pieces ^a	Free shall conform to ISO 18553	ISO 18553	TYPE TEST	ONE / LOT/SIZE

*For Injection Type Transition Fitting (T.F.)

NOTES:

a – The number of test pieces given indicate the numbers required to establish a value for the characteristic described in the table. The numbers of test pieces required for factory production control and process control should be listed in the manufacturer's quality plan. For guidance see EN 1555-7:

- 1-Check for leaks by means of immersion, a soap solution. No leakage shall be seen.
- 2-Refer to clause 8.1
- 3- Group one: TF sizes (25-63) mm
- 4- Group two: TF sizes (90mm and more)
- 5- Increase tensile force until yield of the PE pipe occurs.
- 6- Quantity of TF in each lot:
2000 for size (25-63) mm
500 for size (90-160) mm
250 for size >160 mm

7.0. Minimum length of PE & Steel Part & Steel Part Wall Thickness

7.1. Spigot Type Transition Fitting (T.F.)

TABLE 2

Item	Size mm ×in	Pe part		Steel part	
		Length(mm)	W.T(mm)	Length(mm)	W.T _(in)
1	25 mm X3/4"	230	3.0	163	0.113
2	32mmX1"	230	3.0	163	0.133
3	63 mmX2"	230	5.8	163	0.154
4	90 mmX4"	250	8.2	300	0.172
5	110 mmX4"	300	10.0	300	0.172
6	125 mm X4"	525	11.4	300	0.172
7	90mmX6"	250	8.2	300	0.172
8	125 mmX6"	525	11.4	300	0.172
9	125 mmX8"	525	11.4	300	0.188
10	160 mmX6"	530	14.6	300	0.172
11	160 mmX8"	530	14.6	300	0.188
12	200 mmX8"	550	18.2	300	0.188
13	200 mmX10"	550	18.2	300	0.219
14	200 mmX12"	550	18.2	300	0.250
15	225 mmX10"	550	20.5	300	0.219
16	225 mmX12"	550	20.5	300	0.250

TABLE 3

7.2. Injection Type Transition Fitting (T.F.)

Item	Size mm ×in	Pe part		Steel part	
		Length(mm)	W.T(mm)	Length(mm)	W.T _(i)
1	25 mm X3/4"	135 Acc. To annex3	3&6 Acc. To annex3	250 Acc. To annex3	0.113

8.0. Inspection & Testing

8.1. Type tests shall demonstrate that all transition fitting conform to all requirements for characteristic given in table 1.

In addition, relevant type tests shall be carried out and relevant certificate shall be Submitted whenever there is a change in design, and /or in the production method other than routine in – process adjustment and any change in raw material. In case of no change in mentioned above items every five years the type tests certificate shall be renewed.

9.0. Marking:

Marking shall be engraved mechanically or chemically over the joint section on the spigot .

All TF shall be marked visibly and indelibly with the following data :

TABLE 4

ASPECT	MARK ORSYMBOL
Manufacturer's name or trademark	Name or symbol
Batch. No:	No.
Nominal outside diameter of pipes	DN
PE material and designation	PE100
Design application series	SDR11/ SDR 13.6
Date of manufacturing	Year

10.0. Documentation

10.1. Factory approval test certificate

10.2. Welder qualification certificate

10.3. 3rd party approval test certificate

11.0. Packaging

Each individual T.F. shall be put in plastic bag, sealed and packaged in suitable carton for T.F. up to 90 mm and wooden box for T.F. of size 90 mm and larger , bear at least one label with the manufacturer's name, type and dimensions of the part, quantity in the carton /wooden box and any special storage recommendation by manufacturer .

INFORMATIVE ANNEX 1

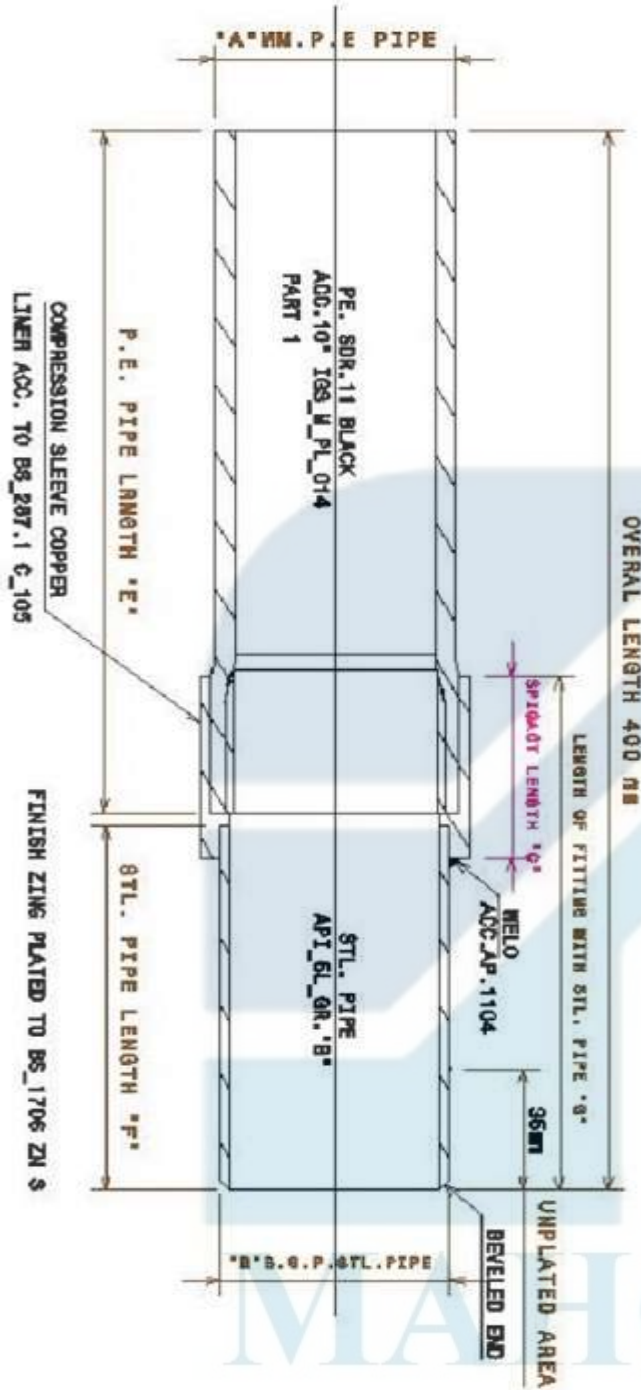

T.F DIMENSION'S FOR SIZE 25mm. UPTO 63mm

ITEM	SIZE	A.B.	C	E	F	G	STEEL PIPE W.T.	SPIGOT_OD
1	25mm*3/4"	46	230	163	200	0.113"	32mm	
2	32mm*1"	46	230	163	200	0.133"	47mm	
3	63mm*2"	53	230	163	200	0.154"	75mm	

INFORMATIVE ANNEX 2

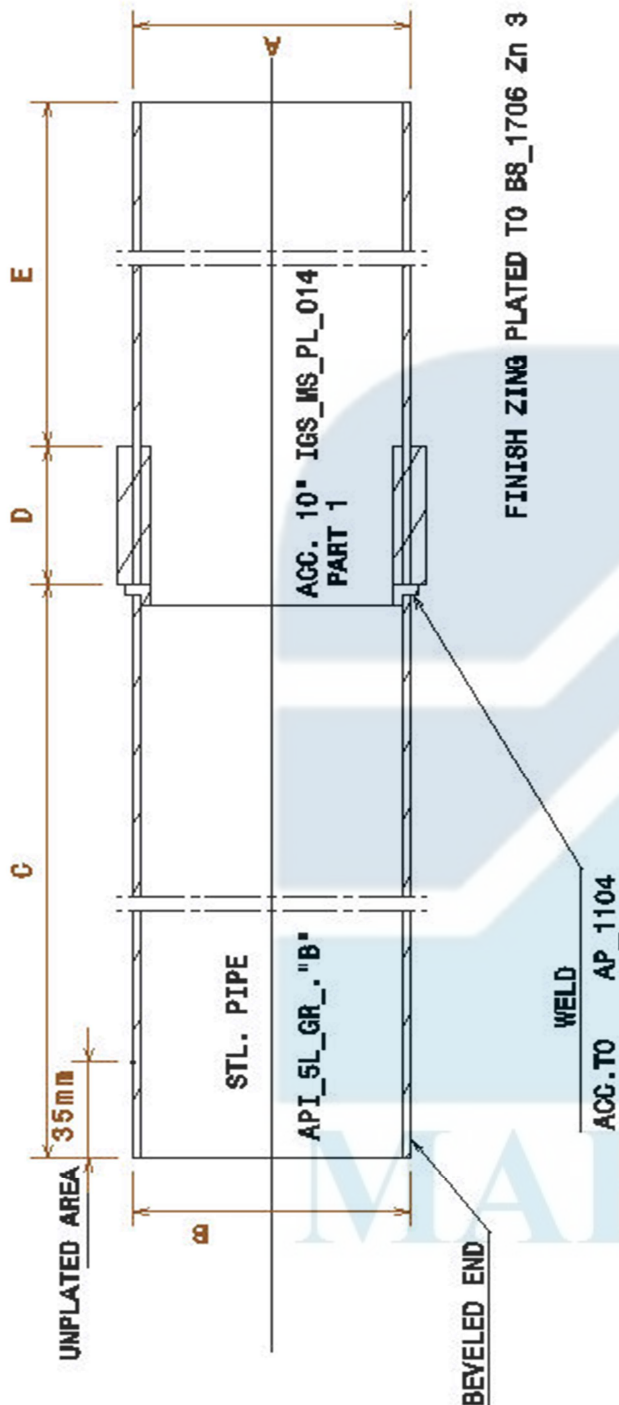

T.F DIMENSION'S FOR SIZW 90mm. UPTO 225mm

ITEM	SIZE A. B. mm * IN.	A (mm)	B (mm)	C (mm)	D (mm)	E (mm)
1	90*4	90	124.3	300	50	250
2	90*6	90	168.3	300	50	250
3	110*4	110	114.3	300	50	300
4	125*4	125	114.3	300	75	525
5	125*6	125	168.3	300	75	525
6	125*8	125	219.1	300	75	525
7	160*6	160	168.3	300	90	530
8	160*8	160	219.1	300	90	530
9	200*8	200	219.1	300	130	550
10	200*10	200	273	300	130	550
11	200*12	200	324	300	130	550
12	225*10	225	273	300	150	550
13	225*12	225	324	300	150	550

**ANNEX 3
(Injection Type TF)**

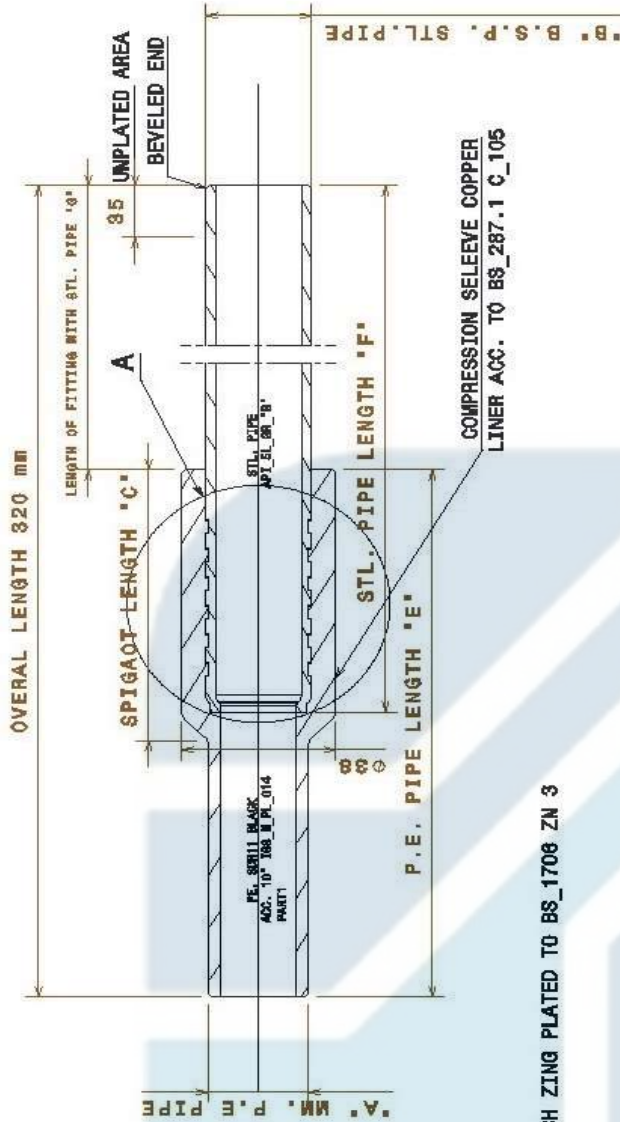

FINISH ZING PLATED TO BS_1706 ZN 3

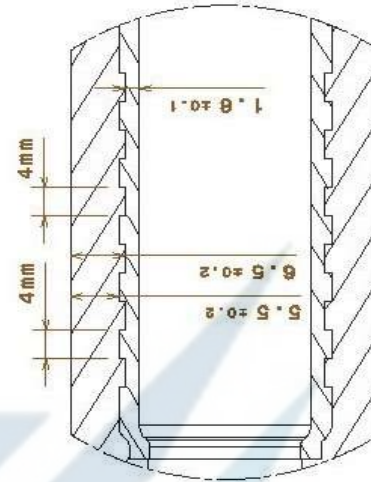

Detail A
Scale: 4:3

T.F DIMENSION'S FOR SIZE 25mm

ITEM	SIZE A.B.	C	E	F	G	STEEL PIPE W.T.	SPIGOT_OD
1	25mm*3/4"	70	135	260	185	0.113"	36mm



INFORMATIVE ANNEX 4

Beside the requirement of IGS-M-PL-014-3 (2) 2018 edition the following points shall be met and demonstrated through proper testing.

- 1- Bend shall be free buckling, cracks, or other evidence of mechanical damage.
- 2- Minimum wall thickness after bending shall not be less than the minimum value permitted according to table 2 of this standard.
- 3- The pipe diameter shall not be reduced by more than 2% of nominal pipe diameter.
- 4- Minimum radius shall not be less than $5 \times OD$.
- 5- Pipe NPT thread in accordance to ANSI B1.20.1.
- 6- Material: steel part according to IGS-M-PL-001-1(1) 2017 seamless.
- 7- This type of T.F can be used just for inner T.F type in accordance to SM- 6231.
- 8- Overall dimension shall be approved by end user.



INFORMATIVE ANNEX 4 (continued)

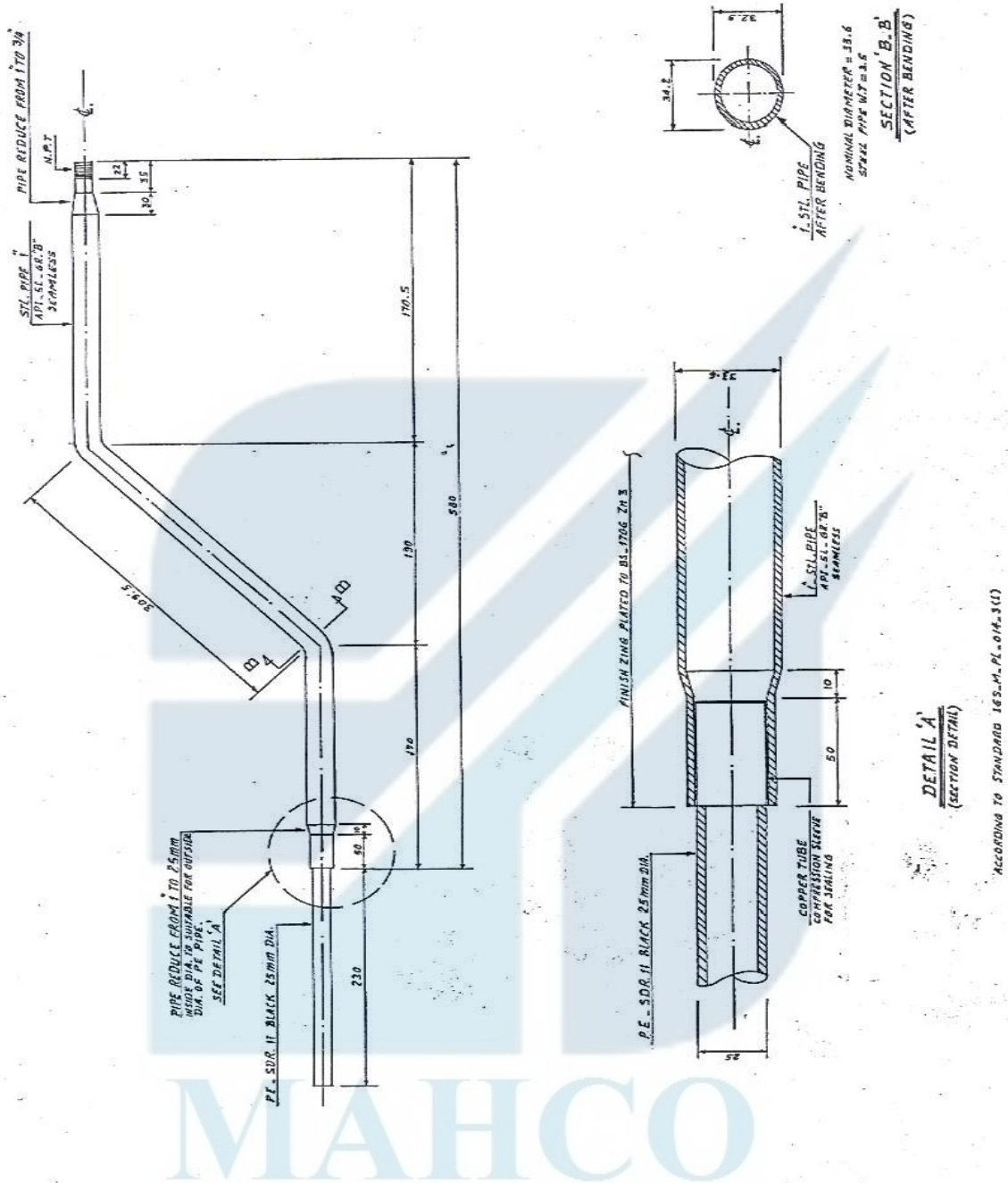

Suitable for use in inside the wall according to SM-6231